



Welcome to the Campo “Field Assist Troubleshooting Guides”.

These guides were developed to assist the working technicians in the field. We’ve supplied issues and solutions to the most common problems encountered in the field. If you need assistance while troubleshooting on the job, they are easy to store in your smart phone, tablet or computer.

Getting Started is easy! Just click on **Page #**
for the problem you are encountering

➤ **Note:** The EB60E is dual voltage, **480 volts** or **600 volts**.

You are connected to **480 volts**...[Page 2](#)

You are connected to **600 volts**...[Page 14](#)



No heat but the fan starts with the fan switch to on...[Page 3](#)

No heat on 20 KW...[Page 11](#)

No heat on 40 KW... [Page 12](#)

No heat on 60 KW or only partial heat...[Page 13](#)

Heater start up and set up...[Page 28](#)

Contact us...[Page 31](#)

No heat and the fan doesn't start...[Page 24](#)

The fan doesn't start with the Off Fan On SW... [Page 24](#)

The fan shuts off before cooling down...[Page 26](#)

The fan won't shut off...[Page 27](#)

Annual Maintenance...[Page 30](#)

There is No Heat.

“Field Assist Troubleshooting Guide”

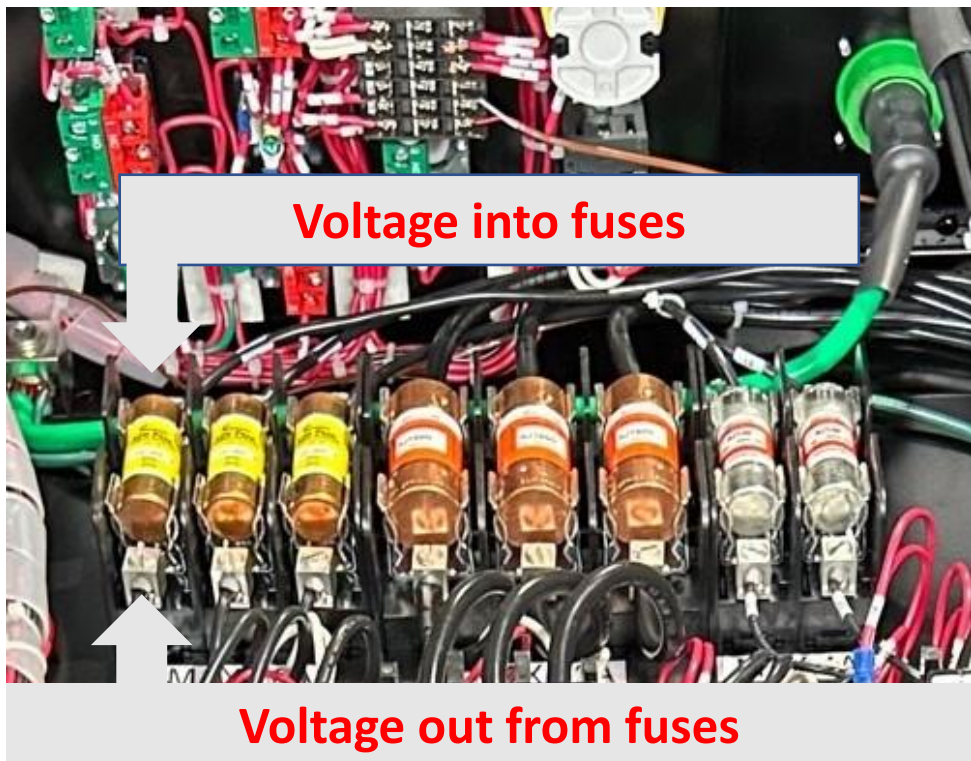

- Check the power supply on the line side of the fuses. Check voltage between all phases and “NOT to ground.”
- On 480 volts L1 to L2, must have 480 volts, L2 to L3 must have 480 volts, L1 to L3 must have 480 volts.
- ✓ If 480 volts not present on one of the phases on the line side of the fuses, Issue with power from land line, or generator or Loose wire connection.
- ✓ If 480 volts not present, on the load side of the fuses on any phase,. Burnt fuse or loose connection.
- If 480 volts is present on all phases,
- Continue...[Page 4](#)

“Getting Started”

“Field Assist Troubleshooting Guide”

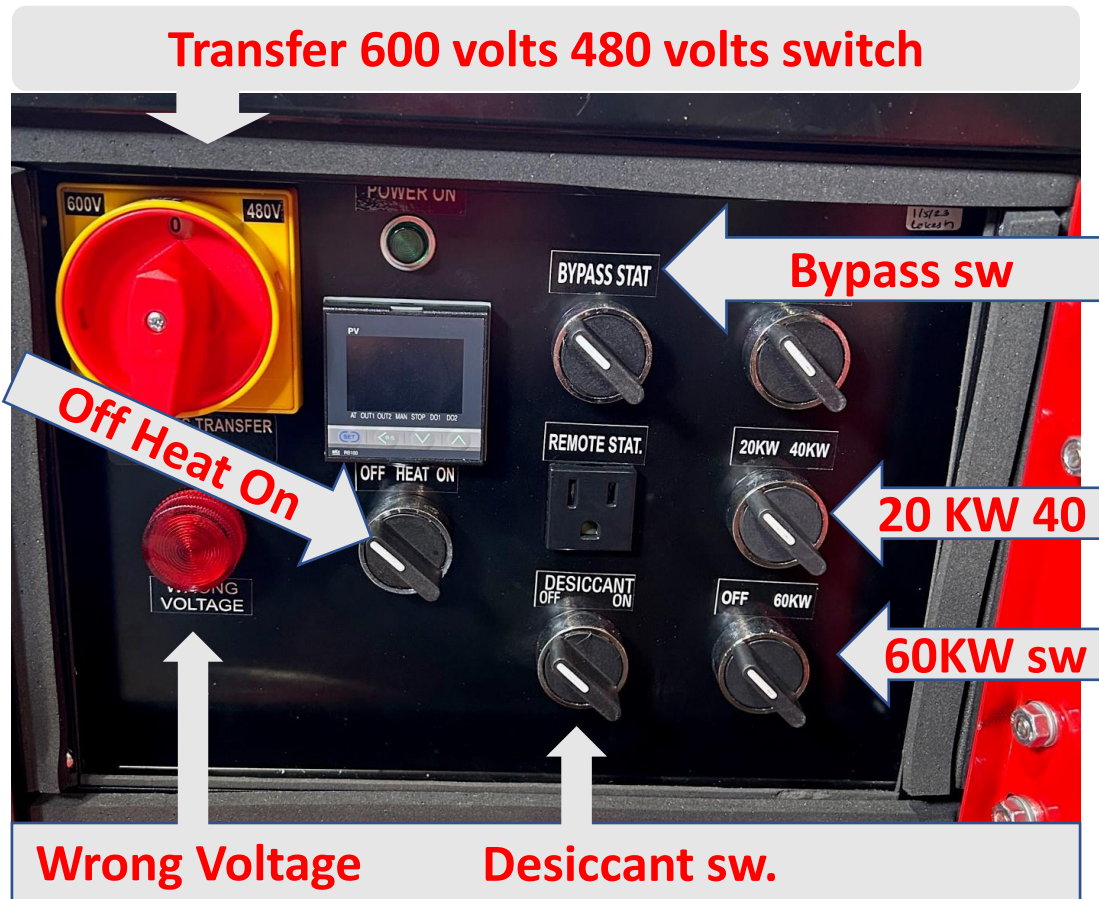

- ✓ Set the transfer switch to **480 volts** with the **power supply off.**
- ✓ Turn the Off Heat On switch to “Heat on”
- ✓ Turn the Bypass Stat switch on.
- ✓ Turn the Desiccant switch to off.
- ✓ Turn the off 60 KW switch to 60 KW on.
- Turn the Off Fan On switch to **on**.
- If the circulating fan starts...[Page 5](#)
- If the circulating fan doesn't start...[Page 24](#)

There is No Heat.

“Field Assist Troubleshooting Guide”



Note: The circulating Fan **must start** first before any of the elements are energized.

- With the **Off Fan ON** switch, in the **on** position, check for **120 volts** on air sw. wire # 9
- If **120 volts** **not** present, turn the fan switch to **off** and continue...[Page 6](#)
- If **120 volts** **is** present, turn the fan switch to off and continue...[Page 8](#)



Circ. Fan



Fan switch



Air switch

There is No Heat.

“Field Assist Troubleshooting Guide”



- Check for 120 volts on Hi limit wire # 3
- ✓ If 120 volts not present, defective Off Heat On switch.
- If 120 volts is present, check for 120 volts on # 20 wire on Hi limit disc.
- If 120 volts not present, defective Hi limit switch.
- If 120 volts is present, check for 120 volts on wire # 5 on temp. controller.
- If 120 volts not present, defective, temperature controller (See “Note”)
- If 120 volts is present, check for 120 volts on Bypass sw. wire # 6.
- ✓ If 120 volts not present, defective Bypass sw.
- If 120 volts is present, check for 120 volts on wire # 4 on R1 relay
- If 120 volts is not present defective R1 relay.
- If 120 volts is present, continue... [Page 7](#)
- **Note:** if the display on the temperature controller is reading odd numbers the thermocouple is defective.

Air switch #9

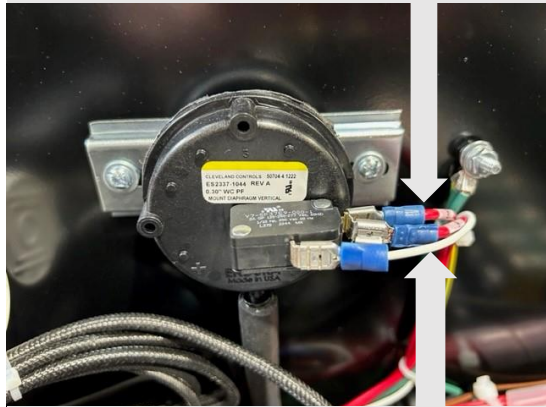

Air switch white wire

- Check for **120 volts** on the air sw. white wire.
 - ✓ If **120 volts** **not** present, defective fan motor **thermostat**.
 - ✓ If **120 volts** **is** present, check for **120 volts** on wire # 9 on air switch.
 - ✓ If **120 volts** **not** present, defective air proving switch.
- **Note:** the fan motor **thermostat** is located inside the fan motor, **it is not field serviceable.**

Problem Solved

There is No Heat.

“Field Assist Troubleshooting Guide”

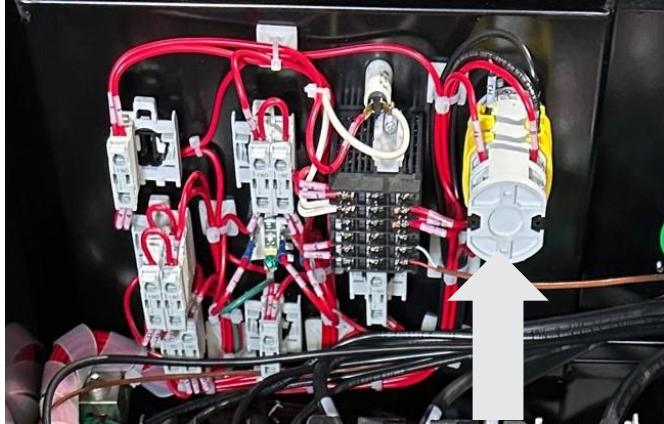

Transfer Switch wire #14

C3 C4

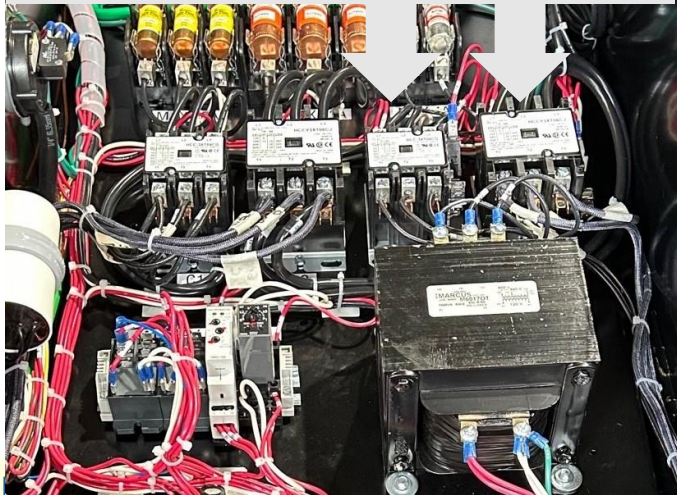

- Check for **120 volts** on wire # 14 on C3 and C4 coil.
- ✓ If **120 volts** not present, defective transfer switch.
- If **120 volts** is present, Check C3 and C4, to see if the black buttons are pulling in on the contactors.
- If **120 volts** is present, and the contacts are not pulling in, defective contactor.
- If the contacts are pulling in, continue...[Page 9](#)

There is No Heat.

“Field Assist Troubleshooting Guide”

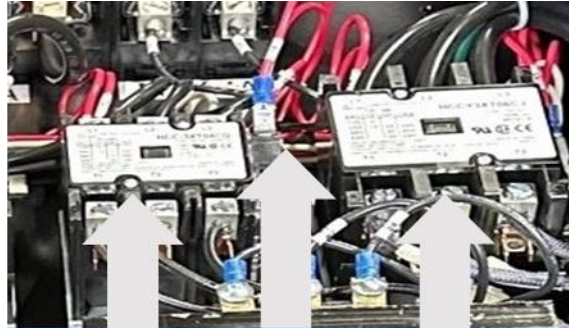

C3 #17 C4

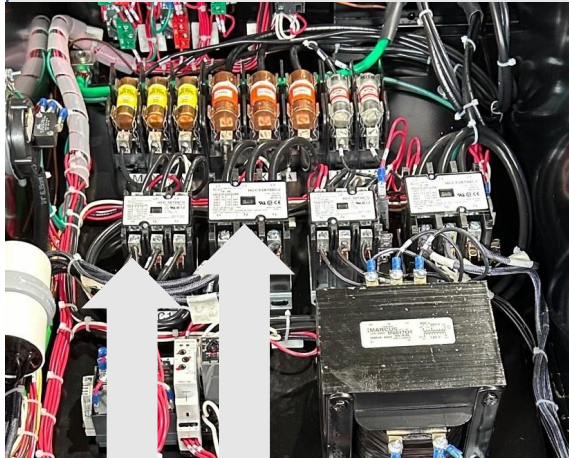

C1 C2 coils

- Check for **120 volts** on wire # 17 of aux contacts C3 and C4
- If **120 volts not** present, both aux. contacts are defective.
- If the 20/40 KW switch is set on **20KW** and the 60 KW set to **60 KW**.
- Check for **120 volts** on wire # 10 on timer.
- ✓ If **120 volts not** present, defective 20 KW selector switch.
- ✓ If **120 volts is** present, check wire # 12 on C1 coil.
- If **120 volts not** present, defective timer.
- If the 20/40 KW switch is set on **40KW** and the 60KW set to **60KW**.
- ✓ Check for **120 volts** on wire # 11 on C2 coil.
- ✓ If **120 volts not** present, defective 40 KW selector switch.
- ✓ If 120 volts **is** present...continue...[Page 10](#)

There is No Heat.

“Field Assist Troubleshooting Guide”



- ✓ If **120 volts** is present, check wire # 10 on timer.
 - ✓ If **120 volts** not present, defective 60 KW switch.
 - ✓ If **120 volts** is present, check for **120 volts** on wire # 12 on C1
 - If **120 volts** is not present, defective timer.
 - If **120 volts** is present, check for **480 volts** between... T1 – T2 and T1 – T3 and T2 – T3. on C1 and C2.
 - ✓ If **480 volts** not present on one of the phases, defective C1 contactor or C2 contactor.
 - ✓ If **480 volts** is present, defective elements.
- **Note:** The elements can be checked by using an amp meter and measuring the current draw through the wires to the elements.

Problem solved

There is No Heat on 20KW. “Field Assist Troubleshooting Guide”

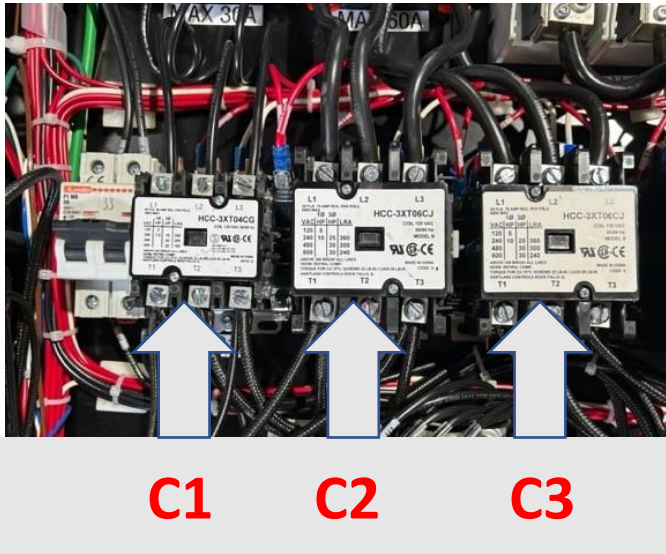
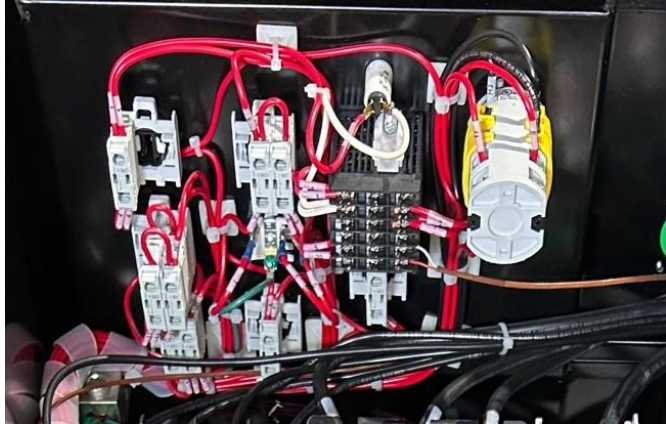

- Set to **20KW**, check for **120 volts** on wire # 10 on timer.
 - ✓ If **120 volts** **not** present, defective selector 20-40 KW switch.
 - If **120 volts** **is** present, check for **120 volts** on C1 wire # 12.
 - If **120 volts** **not** present, defective timer.
 - If **120 volts** **is** present, check for **480 volts** between...
T1 - T2 and T1 – T3 and T2 – T3 on C1 contactor.
 - ✓ If **480 volts** **not** present on all phases, defective C1 contactor.
 - ✓ If **480 volts** **is** present, defective bank of elements.
- **Note:** The elements can be checked by using an amp meter and measuring the current draw through the wires to the elements.

There is No Heat on 40KW. “Field Assist Troubleshooting Guide”

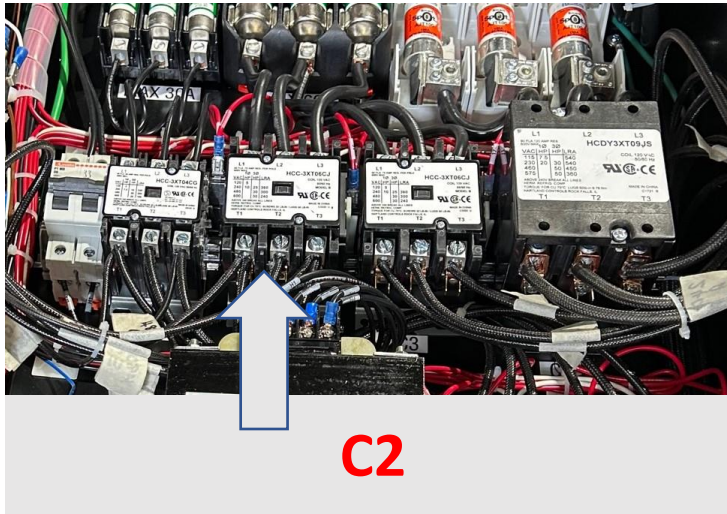

- With the 40 KW switch set to 40KW,
- Check for **120 volts** on wire # 11 of the contactor C 2.
- If **120 volts** **not** present, defective 20/40 switch
- If **120 volts** **is** present, check for **480 volts** between T1 - T2 then T1 – T3 then T2 – T3
- ✓ If **480 volts** **not** present on one of the phases, defective C2 contactor.
- ✓ If **480 volts** **is** present on all phases, defective bank of elements.

➤ **Note:** The elements can be checked by using an amp meter and measuring the current draw through the wires to the elements.

Problem solved

There is No Heat on 60KW or Only Partial Heat

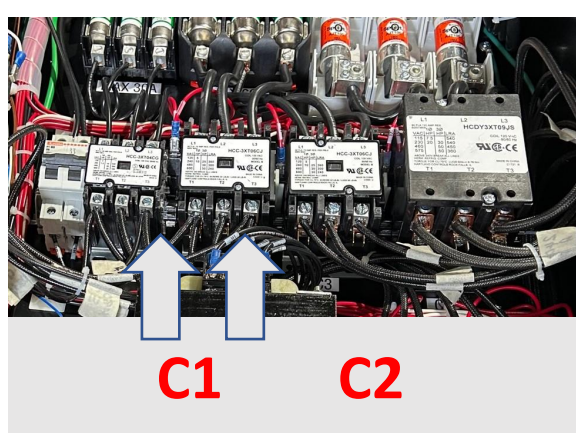

- 60 KW switch set to **60KW** Both contactors C1 and C2 must be closed.
- If only one is closed, you will only have partial heat.
- ✓ If both are open, you will have no heat and C1 and C2 would be defective.
- check for **480 volts** between...
T1 – T2 and T1 – T3 and T2 – T3. on C1 and C2.
- ✓ If **480 volts** **not** present on one of the phases, defective C1 contactor or C2 contactor.
- ✓ If **480 volts** **is** present, defective elements.

Problem solved

EB60E connected to 600 Volts “Field Assist Troubleshooting Guide”



No heat but the fan starts with the fan switch to on...[Page 15](#)

No heat and the fan doesn't start...[Page 24](#)

No heat on 20 KW...[Page 21](#)

The fan doesn't start with the Off Fan On SW... [Page 24](#)

No heat on 40 KW... [Page 22](#)

The fan shuts off before cooling down...[Page 26](#)

No heat on 60 KW or only partial heat on 60 Kw...[Page 23](#)

The fan won't shut off...[Page 27](#)

Heater start up and set up...[Page 28](#)

Annual Maintenance...[Page 30](#)

Contact us...[Page 31](#)

There is No Heat.

“Field Assist Troubleshooting Guide”

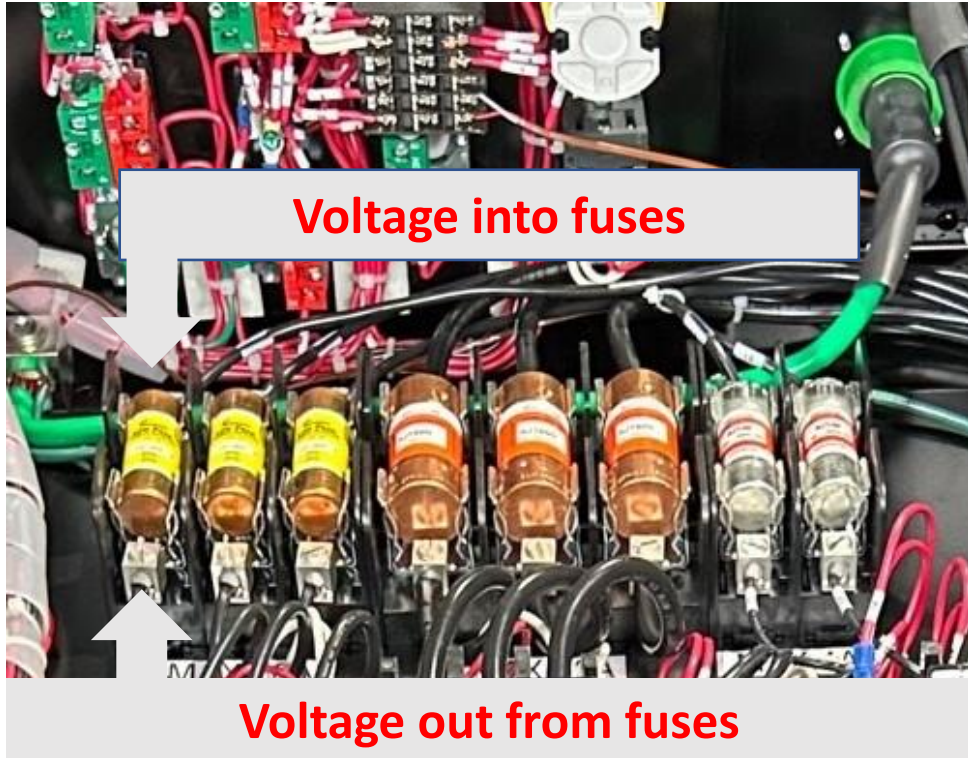

- Check the power supply on the line side of the fuses.
- Check voltage between all phases and “NOT to ground.”
- On 600 volts L1 to I2, must have 600 volts, L2 to L3 must have 600 volts, L1 to L3 must have 600 volts.
- If 600 volts not present on one of the phases on the line side of the fuses, Issue with power from land line, generator. or Loose wire connection.
- ✓ If 600 volts not present, on the load side of the fuses on any phase, burnt fuse or loose connection.
- If 600 volts is present on load side of the fuses, Continue...[Page 16](#)

“Getting Started”

“Field Assist Troubleshooting Guide”

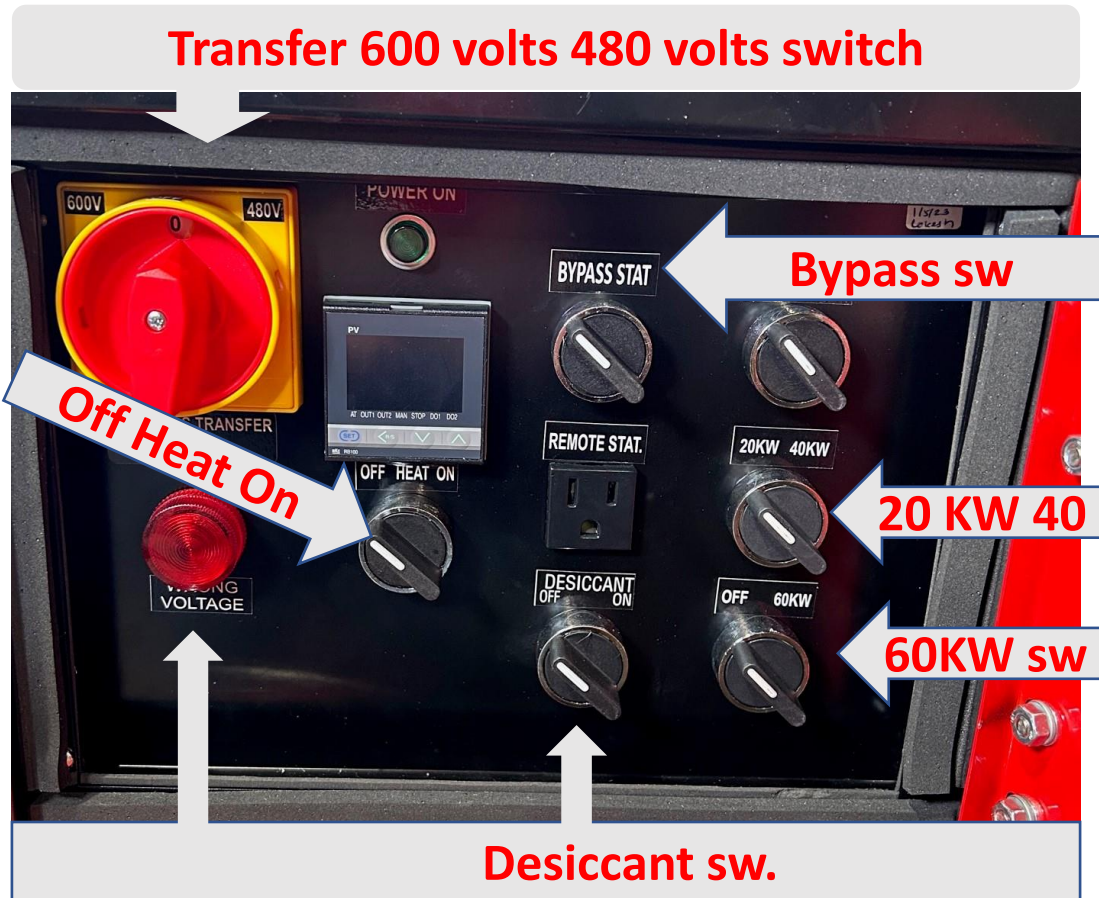

- ✓ Set the transfer switch to 600 volts with the power supply off.
- ✓ Turn the Off Heat On switch to “on”
- ✓ Turn the Bypass Stat switch on.
- ✓ Turn the Desiccant switch to off.
- ✓ Turn the off 60 KW switch to 60 KW on.
- Turn the Off Fan On switch to on.
- If the circulating fan starts...[Page 17](#)
- If the circulating fan doesn't start...[Page 24](#)

There is No Heat.

“Field Assist Troubleshooting Guide”



Circ. Fan

Note: The circulating Fan **must start** first before any of the elements are energized.

- With the **Off Fan ON** switch, in the **on** position, check for **120 volts** on air sw. wire # 9
- If **120 volts** is not present, continue...[Page 18](#)
- If **120 volts** is present, continue...[Page 20](#)



Fan switch



Air switch

There is No Heat.

“Field Assist Troubleshooting Guide”



Bypass Stat wire #6

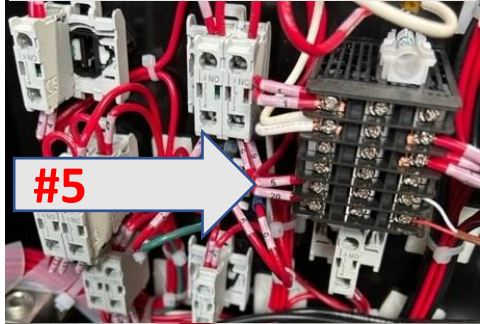

6 R1 relay

- Check for 120 volts on Hi limit wire # 3
- ✓ If 120 volts is not present, defective Off Heat On switch.
- If 120 volts is present, check for 120 volts on # 20 wire on Hi limit disc.
- ✓ If 120 volts is not present, defective Hi limit switch.
- If 120 volts is present, check for 120 volts on wire # 5 on temp. controller.
- ✓ If 120 volts is not present, defective, thermocouple or temp. controller.
- **Note:** if the display on the temperature controller is reading odd numbers the thermocouple is defective.
- If 120 volts is present, check for 120 volts on Bypass sw. wire # 6.
- ✓ If 120 volts is not present, defective Bypass sw.
- If 120 volts is present, check for 120 volts on wire # 4 on R1 relay.
- If 120 volts is not present, defective R1 relay.
- If 120 volts is present, continue... [Page 19](#)

Air switch #9

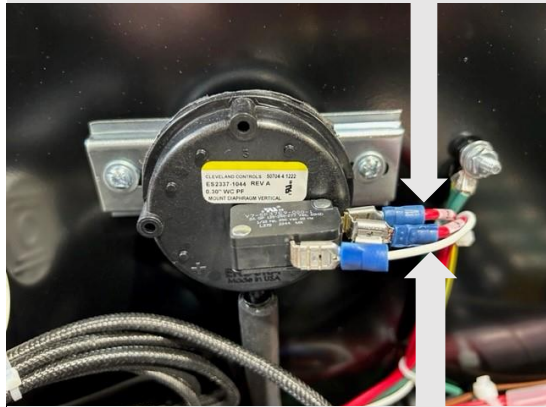

Air switch white wire

- Check for **120 volts** on the air sw. white wire.
 - ✓ If **120 volts** is **not** present, defective fan motor **thermostat**.
 - ✓ If **120 volts** **is** present, check for **120 volts** on wire # 9 on air switch.
 - ✓ If **120 volts** is **not** present, defective air proving switch.
- **Note:** the fan motor **thermostat** is located inside the fan motor, it is **not** field serviceable.

Problem Solved

There is No Heat.

“Field Assist Troubleshooting Guide”

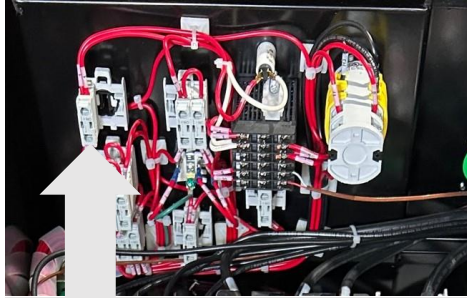

Selector Switch wire #17



C1

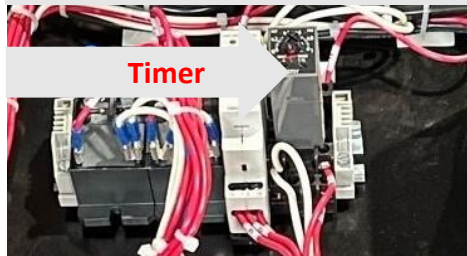

Timer

- Check for **120 volts** on wire # 17 on transfer switch.
- ✓ If **120 volts** is **not** present, defective control transfer switch.
- If the 20/40 KW switch is set on **20KW** and the 60 KW set to **60 KW**.
- Check for **120 volts** on wire # 10 on timer.
- ✓ If **120 volts** **not** present, defective 20 KW selector switch.
- ✓ If **120 volts** is present, check wire # 12 on C1 coil.
- If **120 volts** **not** present, defective timer.
- If the 20/40 KW switch is set on **40KW** and the 60KW set to **60KW**.
- ✓ Check for **120 volts** on wire # 11 on C2 coil.
- ✓ If **120 volts** **not** present, defective 40 KW selector switch.
- ✓ If **120 volts** is present, check wire # 10 on timer.
- ✓ If **120 volts** **not** present, defective 60 KW switch.
- ✓ If **120 volts** is present, check for **120 volts** on wire # 12 on C1
- If **120 volts** is **not** present, defective timer. continue...[Page 32](#)

There is No Heat on 20KW. “Field Assist Troubleshooting Guide”

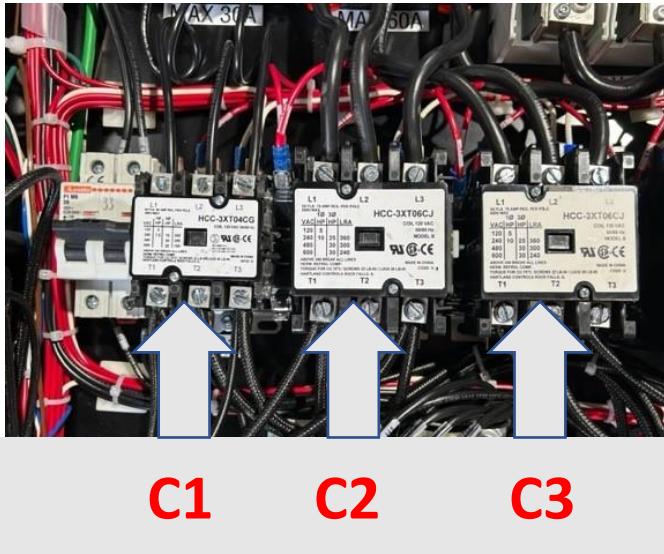
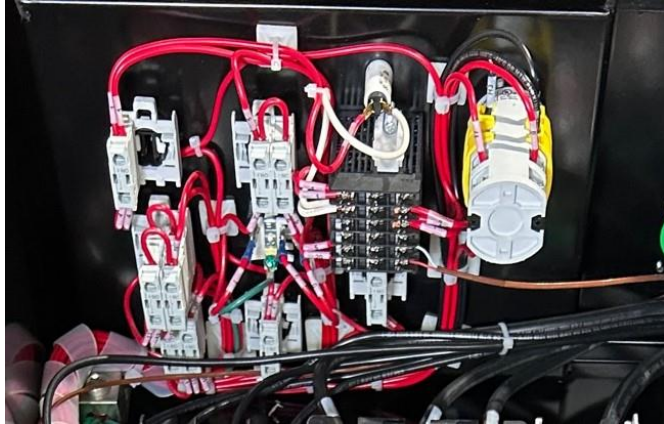

- Set to **20KW**, check for **120 volts** on wire # 10 on timer.
- ✓ If **120 volts** is **not** present, defective selector 20-40 KW switch.
- If **120 volts** is present, check for **120 volts** on C1 wire # 12.
- ✓ If **120 volts** is **not** present, defective timer.
- ✓ If **120 volts** is present, check for **600 volts** between T1 - T2 and T1 – T3 and T2 – T3 on C1 contacts.
- ✓ If **600 volts** is present on all phases, defective bank of elements.
- ✓ If **600 volts** is **not** present on one of the phases, defective C1 contactor.

Problem solved

There is No Heat on 40KW. “Field Assist Troubleshooting Guide”

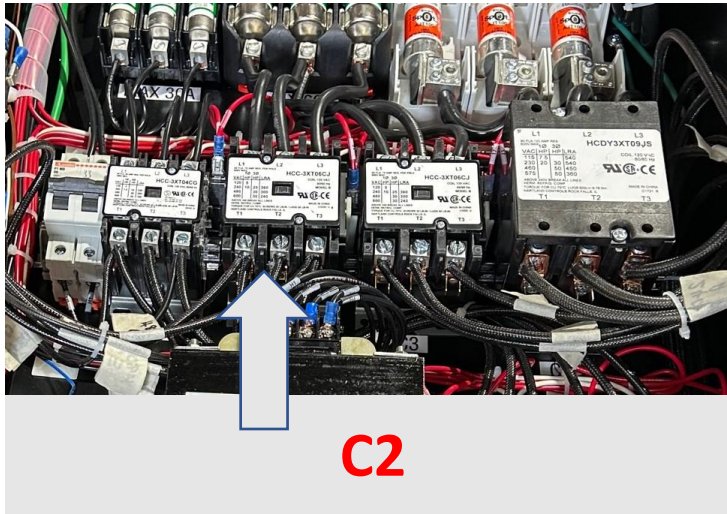

- With the 40 KW switch set to 40KW,
- Check for **120 volts** on wire # 11 of the contactor C 2.
- If **120 volts** **not** present, defective 20/40 switch
- If **120 volts** **is** present, check for **600 volts** between T1 - T2 then T1 – T3 then T2 – T3
- ✓ If **600 volts** **not** present on one of the phases, defective C2 contactor.
- ✓ If **600 volts** **is** present on all phases, defective bank of elements.

➤ **Note:** The elements can be checked by using an amp meter and measuring the current draw through the wires to the elements.

Problem solved

There is No Heat on 60KW or Only Partial Heat

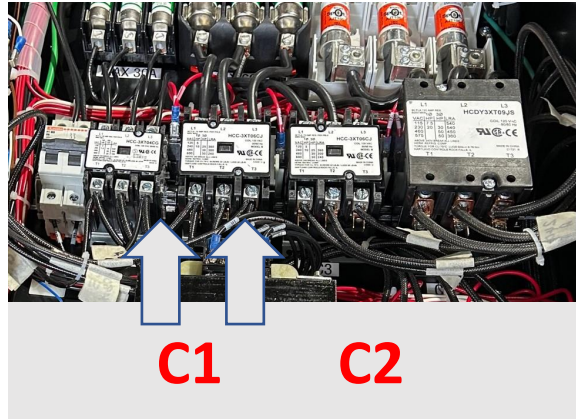

- 60 KW switch set to 60KW **both** contactors C1 and C2 must be closed.
- If only one is closed, you will only have partial heat.
- If both are open, you will have no heat and C1 and C2 would be defective or burnt elements. check for **600 volts** between...
T1 – T2 and T1 – T3 and T2 – T3. on C1 and C2.
- ✓ If **600 volts not** present on one of the phases, defective C1 contactor or C2 contactor.
- ✓ If **600 volts is** present, defective elements.

Checking C1 contactor 20 Kw...[Page 21](#)

Problem solved

Checking C2 contactor 40 Kw...[Page 22](#)

The fan doesn't start.

“Field Assist Troubleshooting Guide”

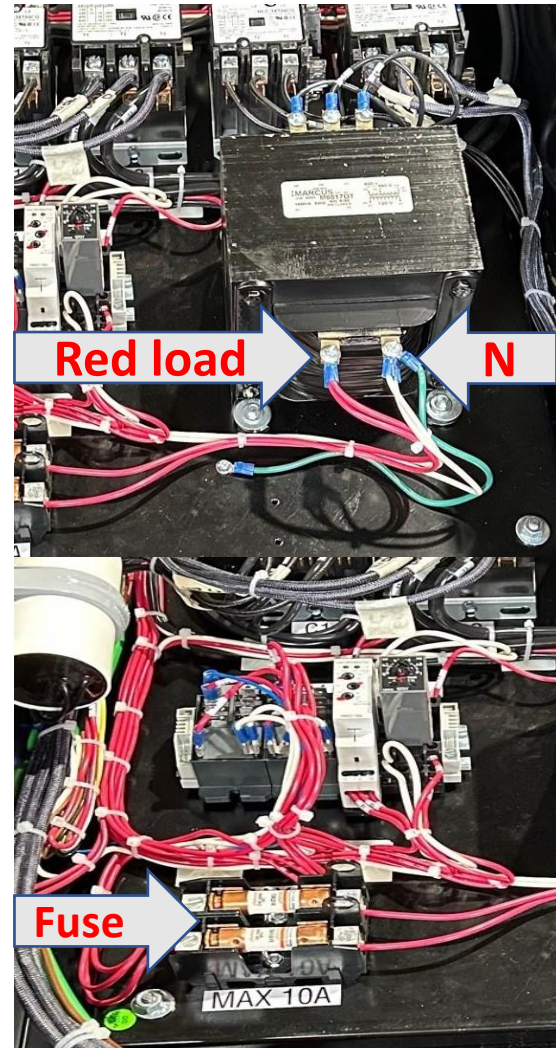

- If You are on **480 volts** or If you are on **600 volts**
 - With the Off fan On Switch in the **on** position, check for **120 volts** on wire # 1 on the VSR relay.
 - If **120 volts not** present, Check for **120 volts** on transformer between the **red** and white wire N.
 - If **120 volts not** present, check for **600V** or **480V** 4-amp fuses-breakers.
 - ✓ If **600** or If **480 volts not** present, burnt fuse or tripped breakers.
 - If **600** or IF **480 volts is** present, defective transformer.
 - If **120 volts is** present, on secondary of transformer, check for... **120 volts** on 2-amp fuse wire # 1A.
 - ✓ If **120 volts not** present, burnt fuse.
 - ✓ If **120 volts is** present, defective VSR relay.
 - If **120 volts is** present on # 1 wire on the VSR relay....
 - Continue... [Page 25](#)

The fan doesn't start on a call for heat "Field Assist Troubleshooting Guide"



10-amp fuse



Relays M1 R1

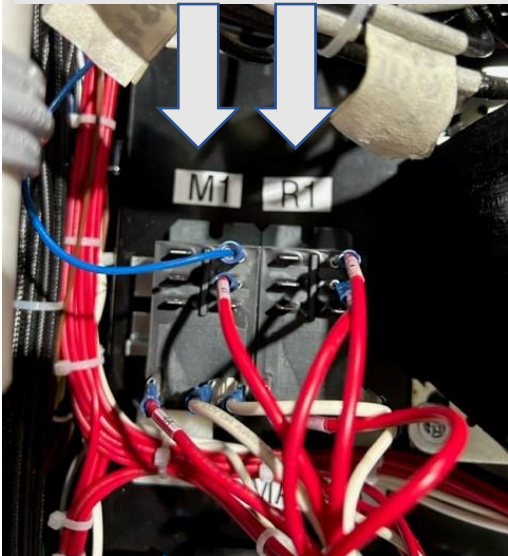

- Check for 120 volts on Off Fan On switch wire # 4.
- If 120 volts is not present, defective fan switch.
- ✓ If 120 volts is present, check for 120 volts on M1 relay wire # 4A
- ✓ If 120 volts is not present, defective desiccant.
- If 120 volts is present, check for 120 volts on M1 relay wire # 21.
- ✓ If 120 volts is not present, burnt 10-amp fuse.
- If 120 volts is present, check for 120 volts on M1 relay blue wire # 22.
- ✓ If 120 volts is not present, defective M1 relay.
- ✓ If 120 volts is present, defective fan motor.

Problem solved

The fan shuts off before cooling down “Field Assist Troubleshooting Guide”



Temperature control

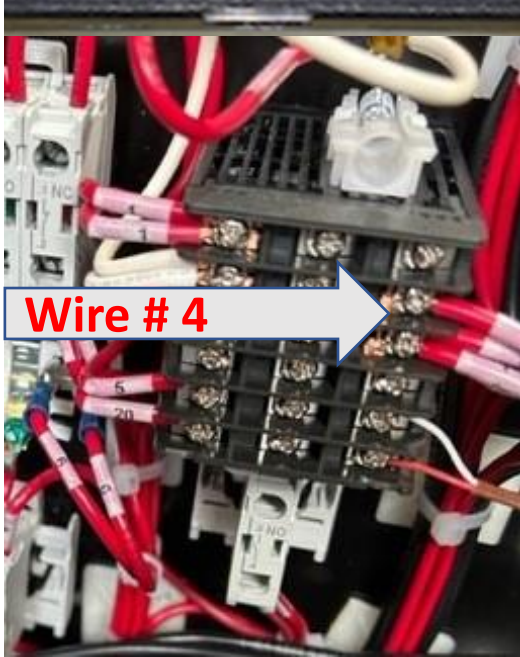

- **Note:** the temperature controller shuts down the fan after the call for heat has ended at 80° F.
- ✓ If the display reads odd numbers, defective thermocouple.
- With the Bypass switch on off and with the display temperature over 80° F.
- If the fan is shutting off as soon as the call for heat has ended, check for 120 volts on wire # 4 on the temperature controller.
- ✓ If 120 volts not present, the temperature controller is defective.

Problem solved

The fan won't shut off.

“Field Assist Troubleshooting Guide”



Temperature control

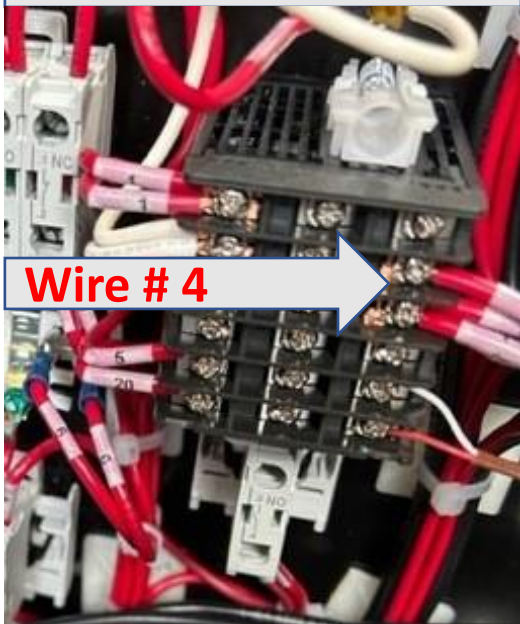

Wire # 4

- **Note:** with the Bypass switch on **off** and with the display temperature under 80° F, the fan must shut off.
- ✓ If the display reads odd numbers, defective thermocouple.
- If the fan continues to run, check for **120 volts** on wire # 4 on the temperature controller.
- If **120 volts** **is** present, defective temperature controller.
- If **120 volts** **not** present, check for 120 volts on wire # 22 on M1 relay.
- If **120 volts** **is** present, defective M1 Relay.

Problem solved

Start-up procedure for electric heaters “Field Assist Troubleshooting Guide”



- Determine the voltage being supplied to the heater, **240 volts** or **480 volts**.
- Determine power cable sizing to feed power to the heater.
- Ensure all connections are tight and properly connected.
- Ensure all lines are properly protected from water, traffic, and other obstructions.
- Before starting the heater, check the voltage supplied to the unit, **240 volts** or **480 volts**.
- Switch the transfer selector switch to the supplied voltage (**240 volts** or **480 volts**)
- **Lock** the switch so **no** mistake can be made by switching to wrong voltage during operation.
- Before starting the heater, with the Off Heat turned off, turn the OFF Fan to **On**.
- If the selected voltage is **240 volts**, with the Fan running, check to ensure the voltage is between **208 volts** and **240 volts**.
- If the selected voltage is **480 volts**, with the Fan running, check to ensure the voltage is between **460 volts** and **490 volts**... Continue...[Page 29](#)

Start-up procedure for electric heaters “Field Assist Troubleshooting Guide”



If the voltage is good, set the 20 KW-40 KW selector switch to 20 KW.

Turn the Off Fan On switch to off. Turn the Off Heat **On** .

Turn the Bypass switch to **on**. Check the voltage.

Turn the selector 20-40 selector to 40 KW and check the voltage.

Turn the 60 KW selector switch to 60 KW and check the voltage.

If all the voltage checks are good, the heater is set to go.

➤ **Note:** If the heater is going to be connected to a generator, always have the heater shut off until the generator is running stable. Ensure the generator is sized to accommodate the heater voltage and amperage draw.

Start-up set up procedure is complete.



- ✓ Inspect all wiring for broken wires or loose connections.
 - ✓ Tighten all high voltage connections and replace if necessary.
 - ✓ Using compressed air blow off all dust from aux contacts.
 - ✓ Using compressed air blow off all dust from electrical components.
 - ✓ Using compressed air blow off all dust from elements.
 - ✓ Check all fuses.
 - ✓ Inspect heater casing for dents or damage, repair or replace if necessary.
 - ✓ Store in clean dry environment.
 - ✓ Tag ready to rent after maintenance.
- **Note:** large dents in heater casing changes the air flow and can cause issues with elements and could cause damage to wires and controls.

Offering... the best technical support in the industry.



“Field Assist Troubleshooting Guide”



sales@campoequipment.com



1-866-323-0042

There is No Heat.

“Field Assist Troubleshooting Guide”

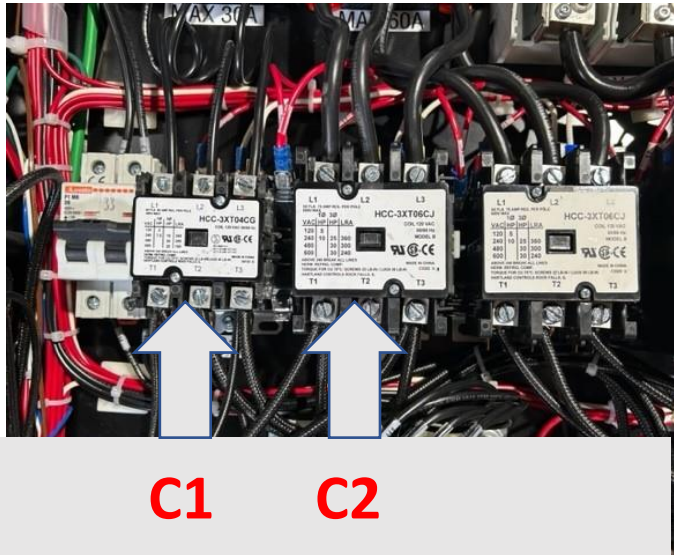

- If **120 volts** is present, check for **600 volts** between... T1 – T2 and T1 – T3 and T2 – T3. on C1 and C2.
- ✓ If **600 volts** not present on one of the phases, defective C1 contactor or C2 contactor.
- ✓ If **600 volts** is present, defective elements.

➤ **Note:** The elements can be checked by using an amp meter and measuring the current draw through the wires to the elements.

Problem solved