



Welcome to the Campo **"Field Assist Troubleshooting Guides"**.

These guides were developed to assist the working technicians in the field. We've supplied issues and solutions to the most common problems encountered in the field. If you need assistance while troubleshooting on the job, they are easy to store in your smart phone, tablet or computer.

Getting Started is easy! Just click on '[Page #](#)'
for the problem you are encountering

- Burner control is locked-out on reset... [Page 2](#)
- Burner control is NOT locked-out on reset and won't start... [Page 24](#)
- **Rigestration, Tech Tips and Bulletins** for you... [Page 58](#)
- **Quick set-up and,** Technical information menu... [Page 41](#)
- **Contact Us...** [Page 59](#)



Choose the issue you are encountering and click on the Page

- Resetting the burner control from Lock-out... [Page 3](#)
- You reset the control, The burner starts , but no flame...[Page 4](#)
- You reset The control and the burner motor did not start and Locks-out on reset...[Page 18](#)
- If the 'Flame Present' Light on the control Is Illuminated before the call For Heat...[Page21](#)
- If A Flame Is Present During The Pre-Purge...[Page 23](#)

Resetting the burner control from Lock-out...

"Field Assist Troubleshooting Guide"

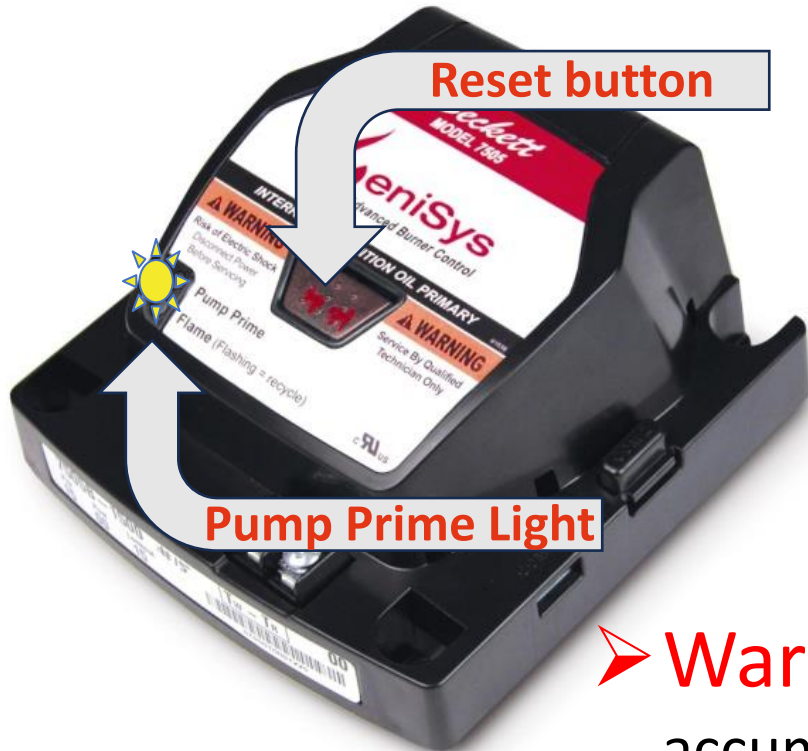

If the reset button light is flashing **red** every half second, this indicates the control is **locked out on safety**. To reset, press and release button. If the reset button light is solid **red**, this indicates the control is in **hard lock-out**. Reset the control by pressing the button for 15 seconds or until the pump prime light is illuminated.

➤ **Warning!** Continuous resetting of the burner control may cause an accumulation of fuel oil in the heatexchanger, and this could lead to an Implosion of the heatexchanger or personal harm.

You reset the control, The burner starts , but no flame...

"Field Assist Troubleshooting Guide"

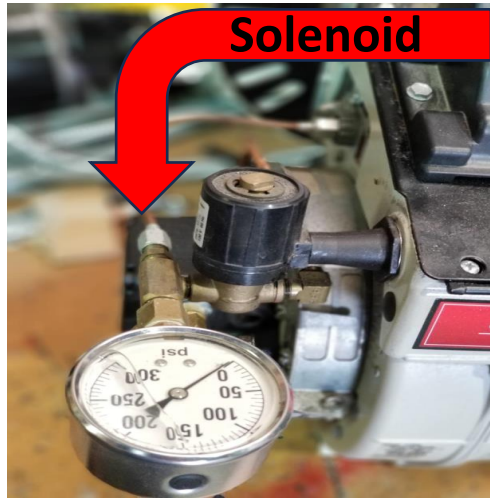

Note: the location of the gauge on the burner and choose page #

- If your gauge is located on the outlet side of the **solenoid** valve... [Page 5](#)
- If your gauge is located on the fuel **pump**... [Page 15](#)

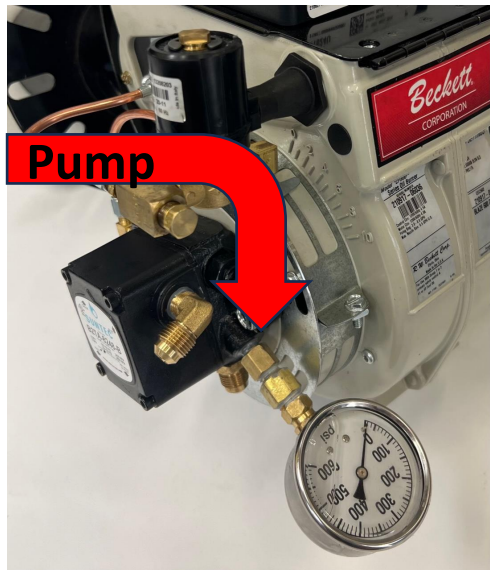

You reset the control, The burner starts , but no flame...

"Field Assist Troubleshooting Guide"

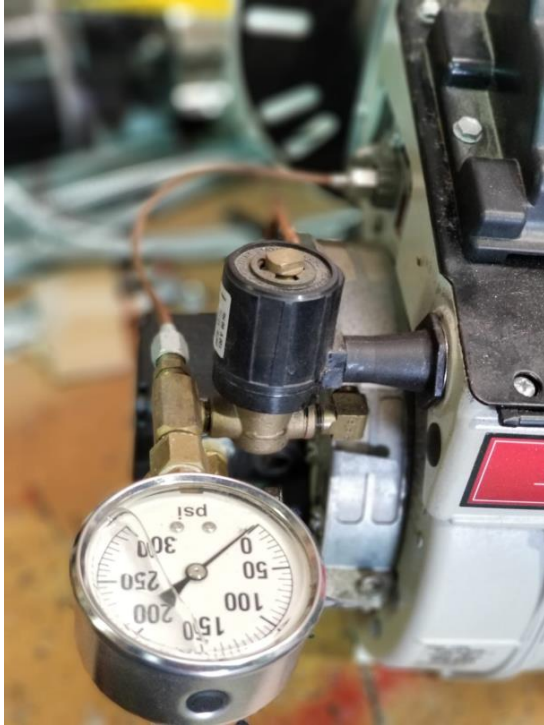

Note: the gauge is located on the outlet side of the solenoid valve

- Reset the control and check the pressure gauge after the **15** second pre-purge.
- ✓ If there is **160 PSI. pressure** after the purge...[Page 6](#)
- ✓ If there is **no pressure** after the purge...[Page 9](#)

[HOME](#)

You reset the control, The burner starts , but no flame...



✓ Defective igniter



✓ Defective electrodes



✓ Water in fuel oil



✓ Defective nozzle



➤ Check the components...[Pages 7](#)

You reset the control, The burner starts , but no flame...

"Field Assist Troubleshooting Guide"



✓ If there is no spark OR the spark is weak, the igniter is defective.

[HOME](#)

- Check the igniter for spark
 - Shut off the power supply to the heater.
 - Open the igniter from the burner housing
 - Remove the cad cell from the igniter base plate
 - Restore power and start the burner.
 - Check for spark across igniter terminals

- **NOTE ensure to use a well insulated screwdriver to test for spark.**

- If the igniter tests good... [Page 8](#)

You reset the control, The burner starts , but no flame...

"Field Assist Troubleshooting Guide"

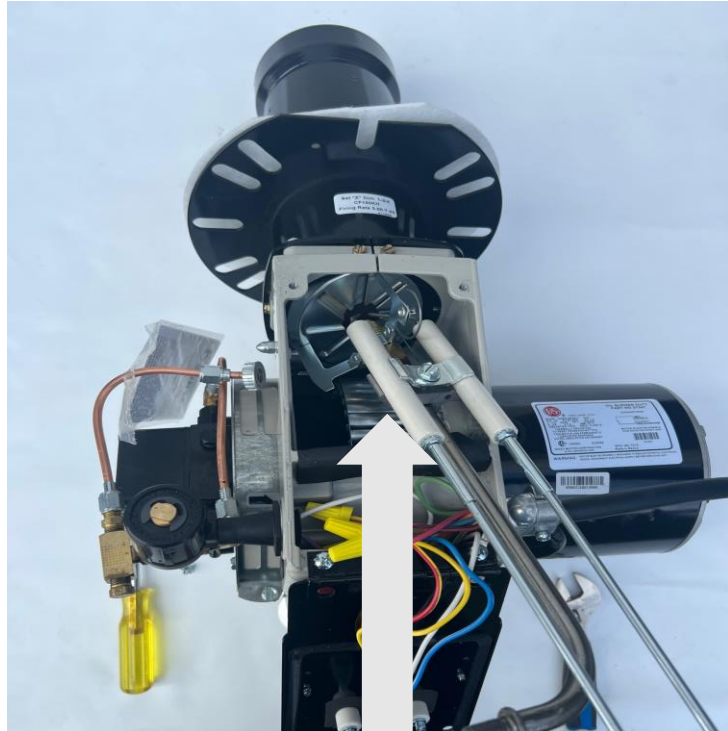

Nozzle line assembly

- Remove the Nozzle Line Assembly...
 - Inspect electrode porcelains for cracks
 - Check for water in nozzle assembly tube.
- ✓ If electrodes are good and there is no water in the oil tube, the nozzle needs to be replaced.



Problem Solved

[HOME](#)

You reset the control, The burner starts , but no flame...

"Field Assist Troubleshooting Guide"

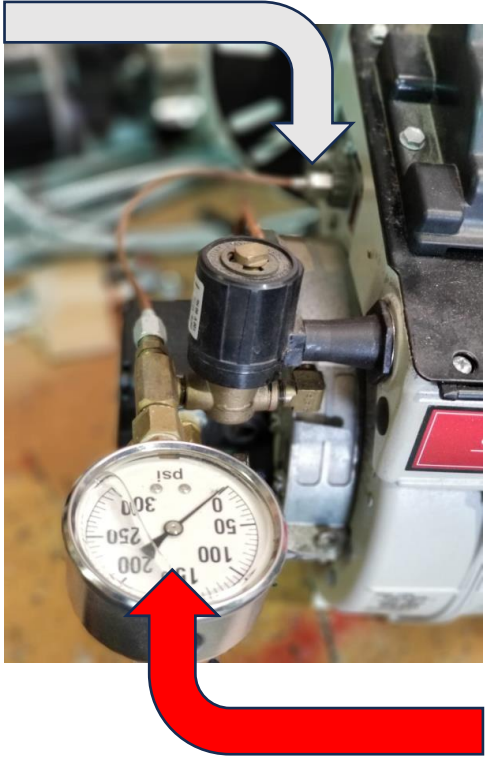

- If there is **no** pressure after the purge...
 - Check the solenoid valve to see if it is opening by removing the oil pressure line from the nozzle line assembly.
 - Place the line pointing into a container and reset the burner.
- ✓ If oil comes out under pressure... [Page 6](#)
- ✓ If no oil comes out... [Page 11](#)
- ✓ Defective pump
- ✓ Broken pump coupling
- ✓ Clogged filters
- ✓ Clogged oil lines
- ✓ No fuel in tank

[HOME](#)

You reset the control the burner starts , but no flame...

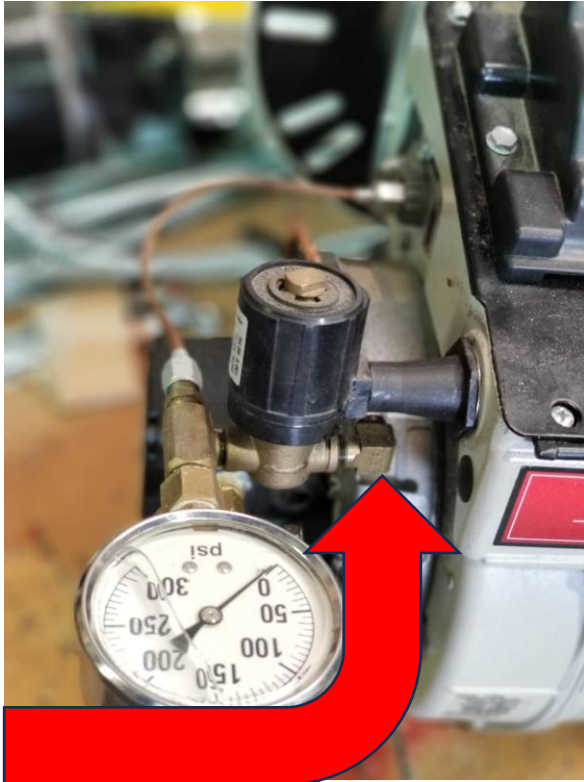

- Remove the oil pressure line that runs from the pump to the solenoid valve *at the valve end only*.
- Direct the line end into a container.
- Start burner to see if oil comes out with pressure.
- ✓ If oil comes out with pressure, the valve is defective.
- Before replacing the valve ensure it has **120 volts** after the purge from control.
- ✓ If **120 volts** is **not** present after the purge, defective control
- If no oil comes out...with the line still off, reset the control 2 or 3 times to ensure the pump has not lost prime.
- If still no oil comes out of the line...[Page 11](#)

You reset the control the burner starts ,
but no flame...

"Field Assist Troubleshooting Guide"



Oil line fitting

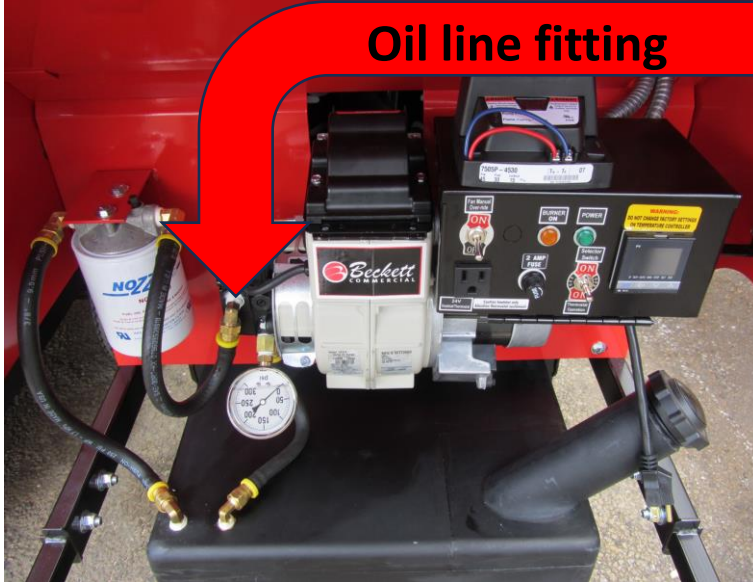

- Remove oil line fitting to the pump and check if there **is fuel** in the pump and oil lines and filter.
- If there is fuel in the filter and lines,
- Defective coupling or defective fuel pump.



➤ Checking the coupling and fuel pump...[Page 12](#)

➤ If there is **NO** fuel oil in the pump and oil line ...[Page 14](#)

Checking the fuel pump and coupling



Remove the pump and coupling. Inspect the coupling to ensure the coupling is fixed secure to both the motor shaft and the pump shaft.



- **NOTE:** If the coupling is good, then the pump is defective. Before replacing the fuel pump...[Page 13](#)

Problem Solved

When Replacing Fuel Oil Pump...!!!!



Special Note!!

You MUST ensure there is a bypass plug installed in the pump when replacing.



Plug Location

Bypass plug port indicated on pump label

When replacing the fuel pump, install the bypass plug into the new pump.

If there is no fuel oil in the pump and oil lines, check for oil in the tank.



- Check for fuel oil in tank



- Check for blocked filter or lines

Problem Solved

You reset the control the burner starts , but no flame...

"Field Assist Troubleshooting Guide"

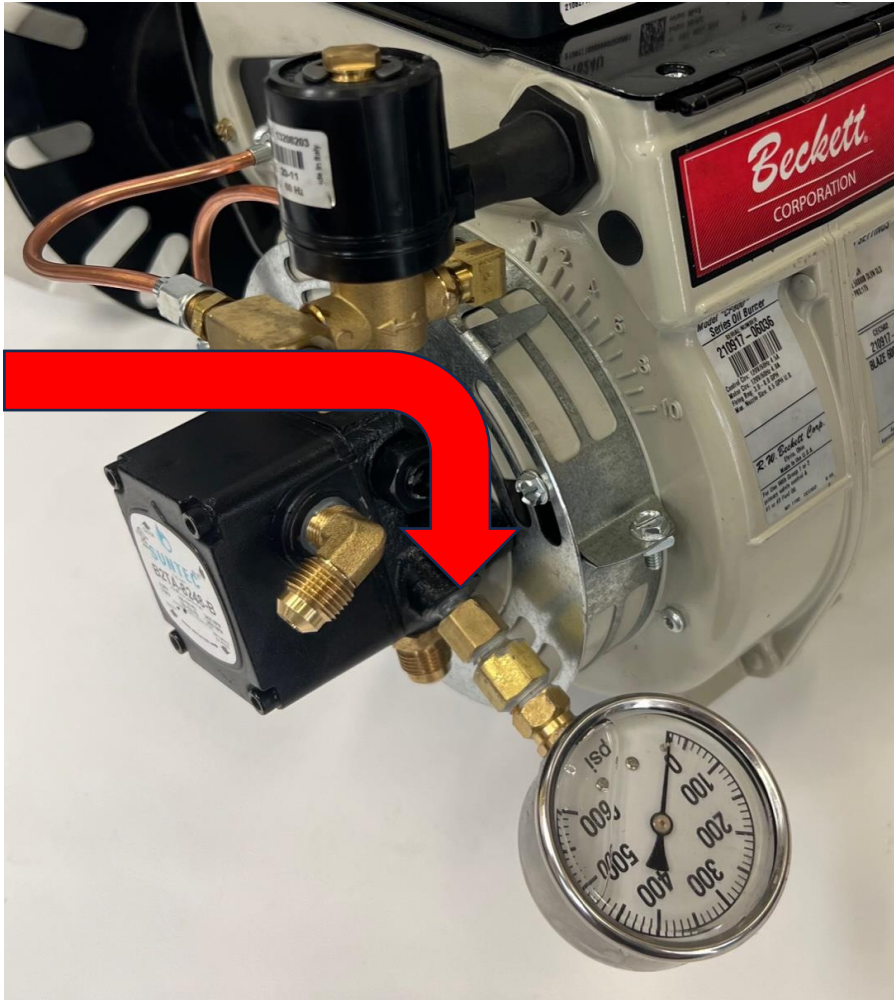

Note: the location of the gauge on the burner.

- ✓ Reset the burner control and check the pressure gauge.

If there **is** 160 PSI... [Page 16](#)

- ✓ If there is **no** pressure... [Page 11](#)

You reset the control the burner starts , but no flame...



If the pressure gauge reads **160 PSI**...

✓ Defective solenoid valve



✓ Defective igniter



✓ Defective electrodes



✓ Water in fuel oil



✓ Defective nozzle



➤ Test the components... [Pages 17](#)

You reset the control the burner starts , but no flame...

"Field Assist Troubleshooting Guide"



- Check the solenoid valve to see if it is opening by removing the oil pressure line from the nozzle line assembly.
- Place the line pointing into a container and reset the burner.
- ✓ If oil does **NOT** flow with pressure, the solenoid is defective.
- Before replacing the valve ensure there is **120 volts** to the valve after the purge from control.
- ✓ If **120 volts** is **not** present after the purge to the valve, defective control.

Problem Solved

➤ If oil is flowing out under pressure... [Page 6](#)

You reset the control. The burner motor did not start and locks-out on reset...

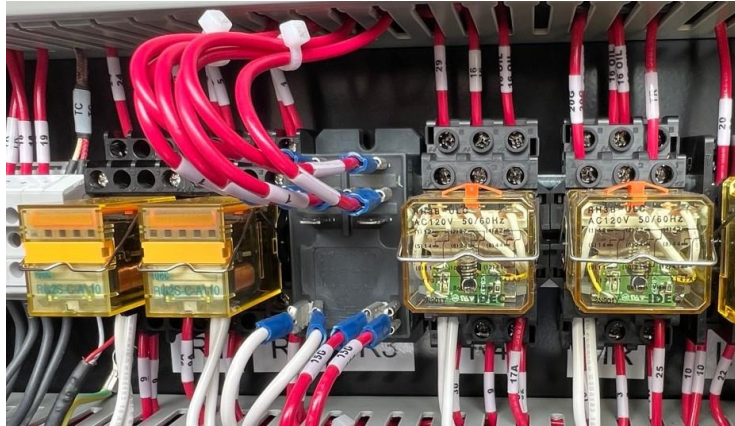

- ✓ Defective burner motor
- ✓ Defective Burner Control
- ✓ Defective Motor Relay



➤ Test the components... [Page 19](#)

Checking burner motor, motor relay and burner control

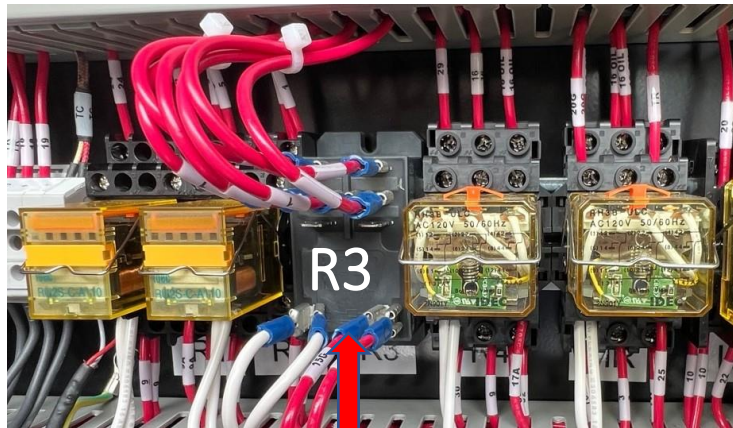

R3 wire #15G

Reset burner control, then check for **120 volts** on burner motor relay R3 coil **#15G**

- ✓ If **120 volts** is **NOT** present, defective burner control
- ✓ If 120 volts is present, defective burner motor relay R3 OR burner motor



➤ Checking burner motor and motor relay...[Page 20](#)

Checking burner motor and motor relay (continued)



R3 wire #19

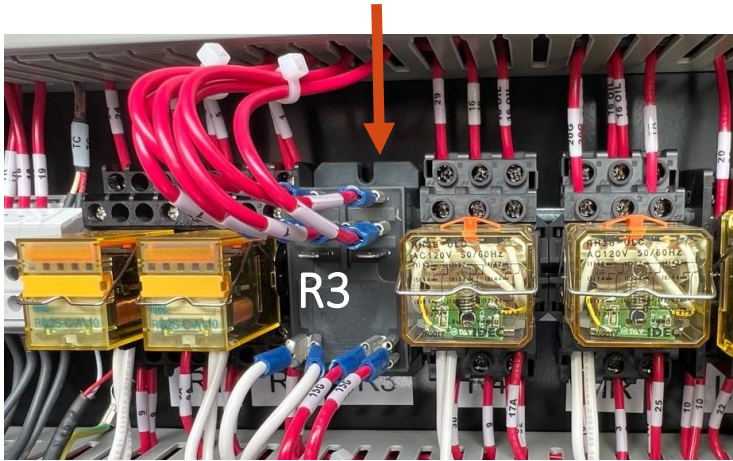

Reset the burner control and check for **120 volts** on burner motor relay (R3) on the motor feed terminal.
(wire #19)

- ✓ If **120 volts** is present, defective burner motor.
- ✓ If **120 volts** is **NOT** present, defective burner motor relay.



➤ Make sure the burner motor reset is not locked out.

[HOME](#)

Problem Solved

If the 'Flame Present' light on the control is illuminated *BEFORE* the call for heat..



Flame Present Light



- ✓ There is a short in the cad cell
- OR
- ✓ There is a short in the cad cell harness



➤ Testing the cad cell or harness... [Page 22](#)

Testing the cad cell.

Remove the cad cell from the harness.

- ✓ If the green light remains ON, the harness is defective.
- ✓ IF the light goes out, the cad cell is defective.



Problem Solved



If there is a flame during the pre-purge...

If there is a flame during the pre-purge...



✓ Defective solenoid valve



Problem Solved



The burner control is NOT locked out on reset

Choose the issue you are encountering and click on the Page #

- If The Burner Control Is NOT Locked Out On Reset And Will Not Start... [Page 25](#)
- If the 'overheat reset' light is illuminated and will not reset... [Page 39](#)
- If The circulating Fan Fails To Start... [Page 33](#)
- If the circulating Fan Does Not Shut Off automatically... [Page 36](#)



The burner control is NOT locked out on reset

Before Proceeding, It is **important** to check voltage from Line L1 and L2, **“Not”** to ground. Please make sure...

1. ...the main power switch is in the **ON** position
2. ...the 'gas/oil switch' is in the **oil** position
3. ...the 'controls' switch is in the **ON** position
4. ...the bypass toggle switch is **on**.
5. ...the Heat/off/Fan switch is **on heat**

Proceed to....[PAGE 26](#)

[HOME](#)

NOTE: Checking the Main Switch and Breakers

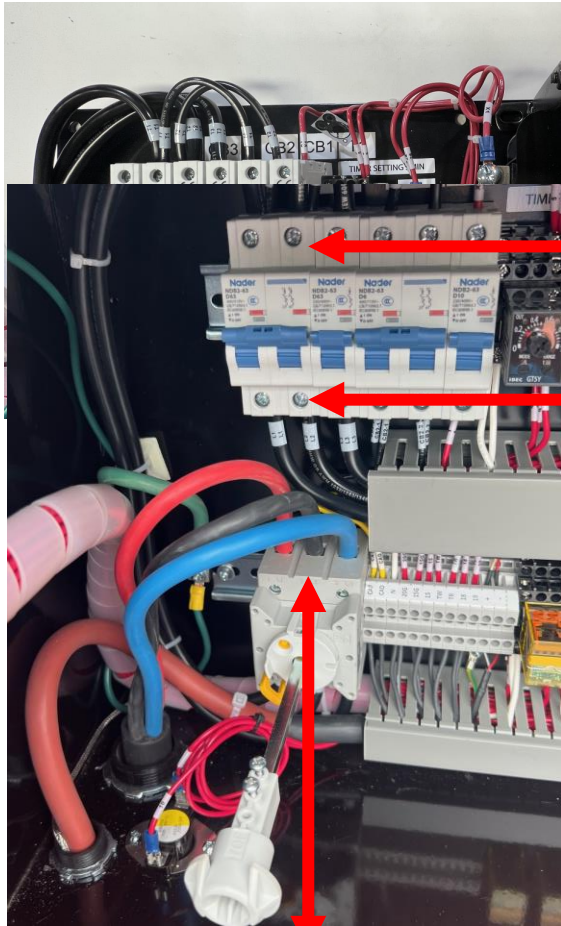

Main Switch

Check voltage between Line L1 and L2, “Not” to ground

- Check for **208 to 240 volts** on the Top of the “Main Switch”.
✓ If **no** voltage present on top of main switch, power supply issue.
- Check for **208 to 240 volts** on CB3 line side. L1 and L2
✓ If **no** voltage between L1 and L2 line side, defective main switch.
- Check for **208 to 240** volts on CB3 Load side L1 and L2
✓ If **no** voltage on load side, the breaker is off or defective.

➤ Continue to... [Page 27](#)

If the burner control is NOT locked out on reset and will not start...

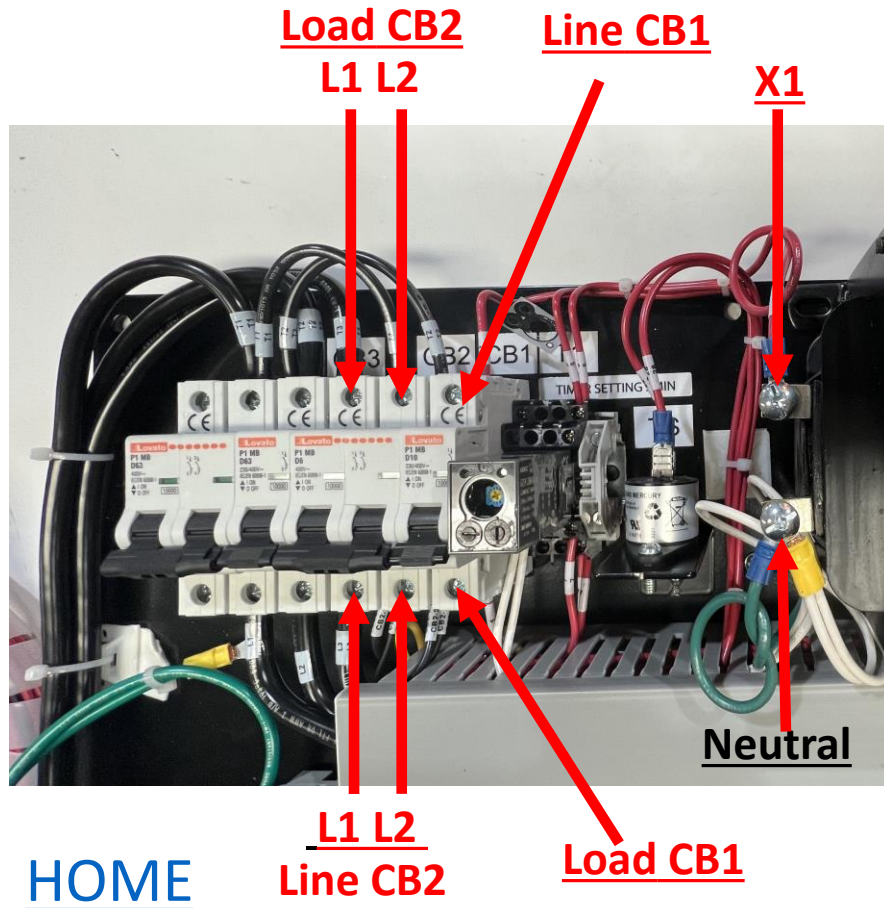

- Check for **208 to 240 volts** between L1 and L2 on CB2 Line side.
- Check for **208 to 240 volts** between L1 and L2 on CB2 Load side.
- ✓ If **208 to 240 volts** is **NOT** present, defective breaker or tripped off.
- Check for **120 volts** on CB1 Line side and Neutral
- ✓ Check for **120 volts** on CB1 Load side and Neutral
- ✓ If **120 volts** is **NOT** present on CB1 Line side,
- ✓ defective transformer.
- If **120 volts** is present... [Page 28](#)

If the burner control is NOT locked out on reset and will not start...

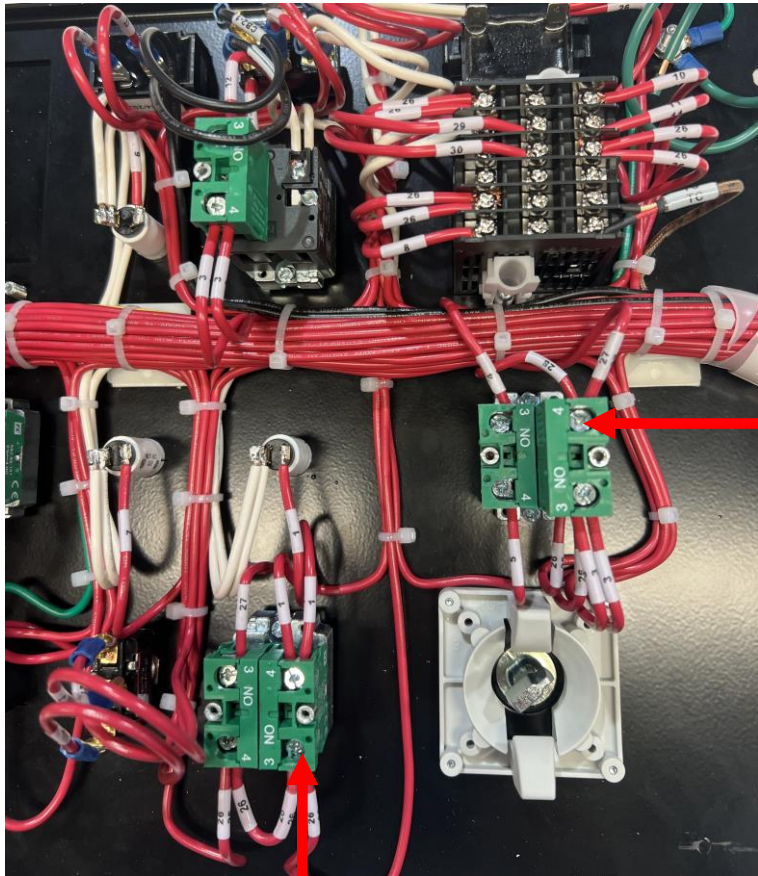

#26

#28

- If 120 volts is present on CB1...
- Check for 120 volts at 'control switch' wire #26
- ✓ If 120 volts is NOT present... defective switch.
- If 120 volts is present, check for 120 volts on 'Heat/Fan switch' wire #28
- ✓ If 120 volts is NOT present, defective 'Heat/Fan switch.
- If 120 volts is present on Heat/Fan switch wire #28
- Continue... [Page 29](#)

If the burner control is NOT locked out on reset and will not start...

Tilt SW
#22

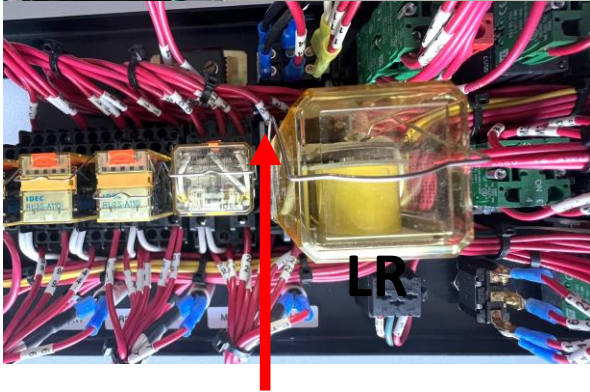
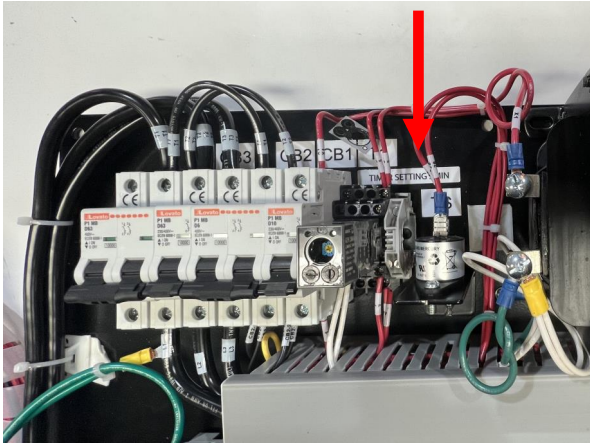

LR #20 oil

- Check for **120 volts** on 'tilt switch' wire #22
- ✓ If **120 volts** is **NOT** present, defective 'tilt switch'
- If **120 volts** is present, check for **120 volts** at LR wire #20 oil
- ✓ If **120 volts** is **NOT** present, defective LR relay
- If **120 volts** is present at LR wire #20 oil...[Page 30](#)

If the burner control is NOT locked out on reset and will not start...

R1 #24

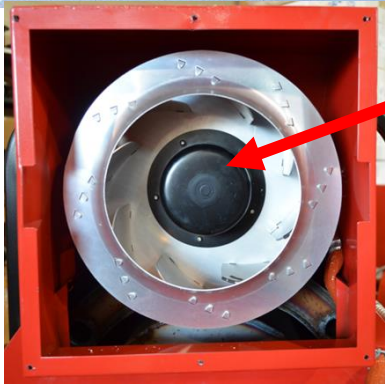
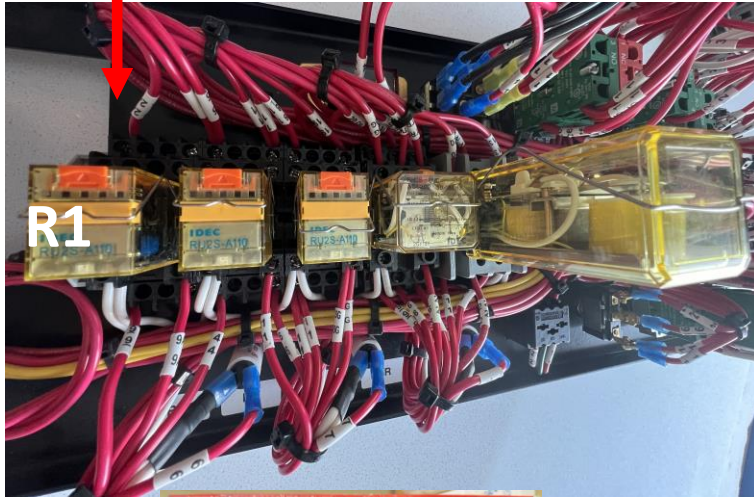

- Check for **120 volts** at R1 wire **#24**
- ✓ If **120 volts** is NOT present, defective circulating fan motor **thermostat**.
- **Note:** the fan motor thermostat is located **inside** the fan motor and is **not** field serviceable.
- ✓ Have the motor sent to a motor repair shop to replace the thermostat or replace with a new fan.

[HOME](#)

➤ If **120 volts** is present at R1 wire **#24**...[Page 31](#)

If the burner control is NOT locked out on reset and will not start...

R4 #16

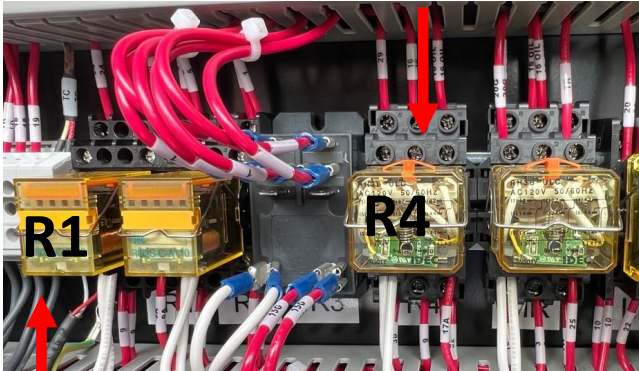

R1 # 9

MR #20G

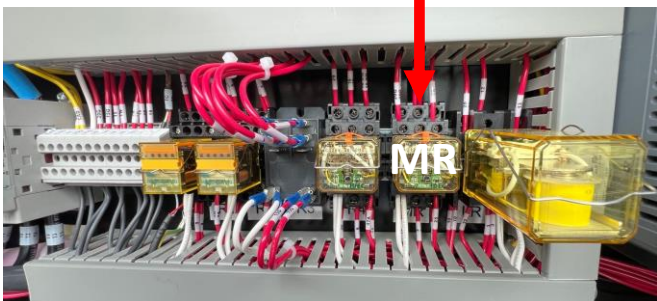

- If 120 volts is present, check for 120 volts at R1 wire #9
- ✓ If 120 volts is NOT present at R1 wire #9, defective R1 relay
- If 120 volts is present, check for 120 volts at R4 wire #16
- ✓ If 120 volts is NOT present, defective R4 relay
- If 120 volts is present, check for 120 volts at MR wire #20 oil
- ✓ If 120 volts is NOT present, defective MR relay

[HOME](#)

Problem Solved

For future use



[HOME](#)

If the circulating fan does not start when the temperature controller reaches 90°F...

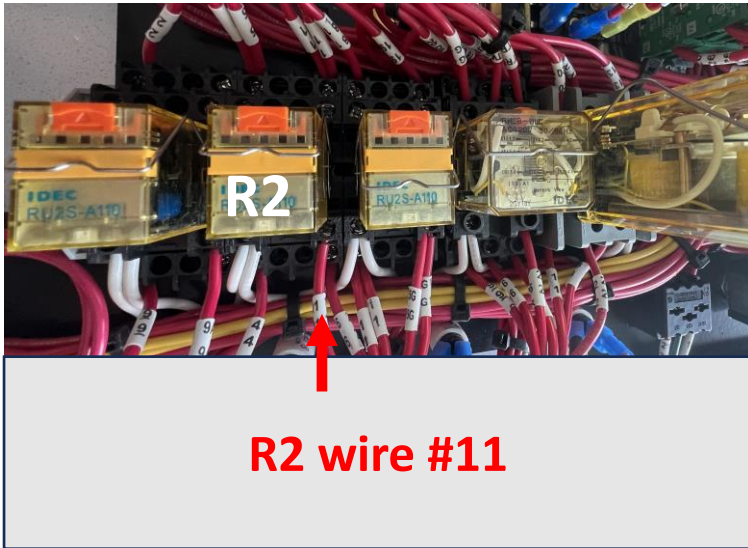

- Check for **120 volts** at R2 relay wire **#11**.
- If **120 volts** is present, defective R2 relay
- If **120 volts** is **NOT** present...



✓ Defective temperature controller.



✓ Defective thermocouple



✓ Defective timer



✓ Defective VFD



✓ Defective Fan speed switch.



[HOME](#)

➤ Check the components... [Page 34](#)

Testing, thermocouple, temperature controller and timer...



- **Note:** The heater is equipped with multiple switches to insure positive start of the circulating fan. It is very unlikely that all switches would be defective.



Testing temperature controller. When the display temperature reaches **90° F** check for **120 volts** on wire **# 11** on temperature controller.

✓ If no voltage present, defective temperature controller.



Testing thermocouple. If the display reads odd numbers...[Page 56](#)



Testing the fan timer. After the burner has run for **2 minutes**, place a jumper between **#4** and **#5** wires. If the fan starts, defective timer.

Testing the fan speed switch. Place a jumper between **#M1** and **#M3** wires on the back of the switch. If the fan starts, defective speed switch.

[HOME](#)

- If the fan doesn't start, check the VFD...[Page 35](#)

If the circulating fan fails to start or not stop Testing the VFD (Variable Frequency Drive)

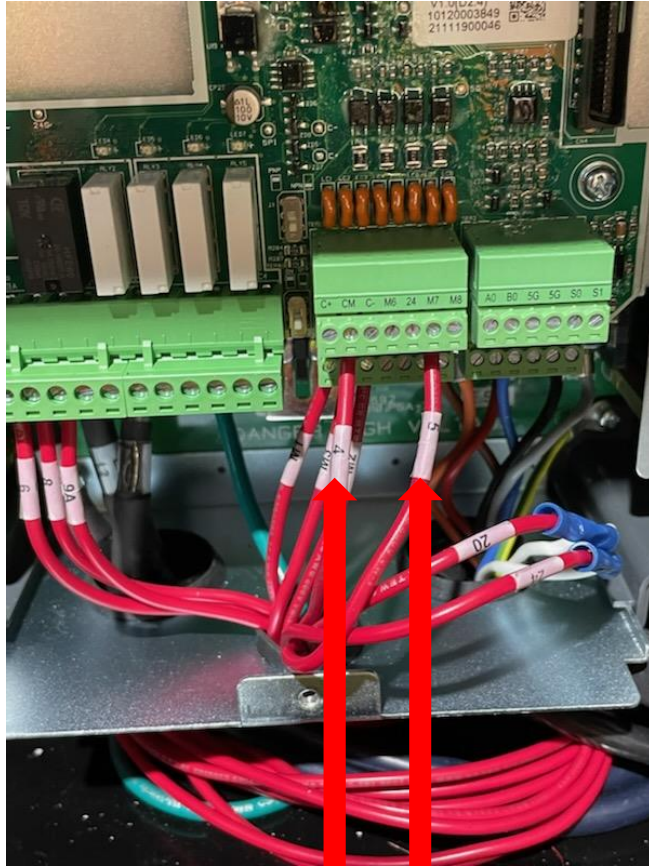

Make sure **208 to 240 volts** is being supplied to the VFD

1. Turn off power to the heater.
 2. Remove the cover of the VFD.
 3. Ensure that all wires are secured to the terminals.
 4. Ensure the terminal blocks are secured properly into place.
 5. Restore power to the heater.
 6. Place a jumper between CM **#4** wire and M7 **#5** wire.
- ✓ If the fan doesn't Start the VFD is Defective

- If fan doesn't stop running, remove wire **#4**
- ✓ If the fan stops the VFD is Defective

HOME

#4 #5

Problem Solved

If the circulating fan does not shut off automatically...

If the circulating fan does not start...



R2 wire #11

➤ Check the components... [Page 37](#)

- Check for 120 volts at R2 relay wire #11.
- ✓ If 120 volts is **Not** present, defective R2 relay
- If 120 volts **is** present...



- ✓ Defective temperature controller.



- ✓ Defective thermocouple



- ✓ Defective timer



- ✓ Defective VFD



- ✓ Defective fan switch



[HOME](#)

If the circulating fan does not shut off automatically...



- Testing temperature controller. with the display temperature under 80° F check for 120 volts on terminal wire #11
- ✓ If 120 volts is present, defective temperature controller.



- Testing thermocouple. If the display reads odd numbers....[Page 56](#)



- Testing the fan timer. With the burner not running, check for 120 volts on terminal wire #4 and #5
- ✓ If 120 volts is present, defective fan timer.
- ✓ If 120 volts is not present, check the VFD...



- Testing the fan speed switch. Remove wire #M1 on the back of the switch. If the fan stops, defective speed switch.

➤ Checking the VFD...[Page 35](#)

For future use





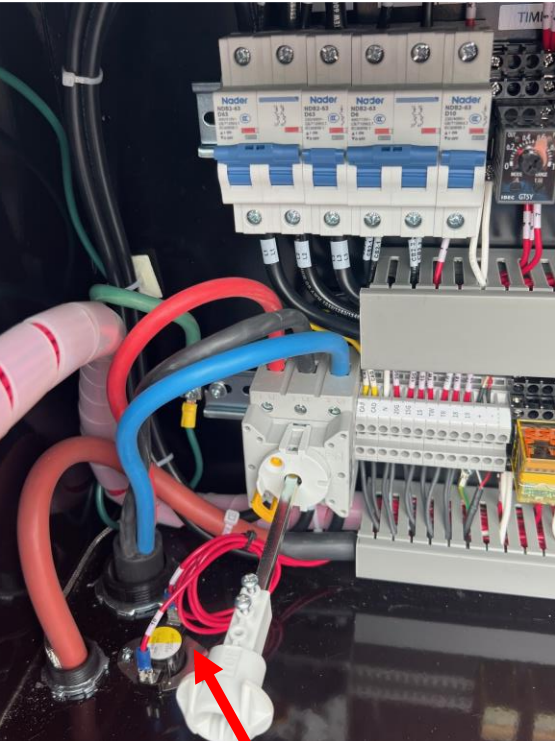

If the 'overheat reset' light is illuminated and will not reset...



#10
150°F thermal limit disc

Check for **120 volts** at wire **#10** on the 150°F thermal limit disc

- If **120 volts** is present...
 - ✓ Defective 150°F thermal limit 
 - ✓ Defective LR Relay 
 - ✓ Defective temperature controller 
 - ✓ Defective thermocouple 

➤ Testing the components... [Page 40](#)

If the 'overheat reset' light is illuminated and will not reset...

"Field Assist Troubleshooting Guide"

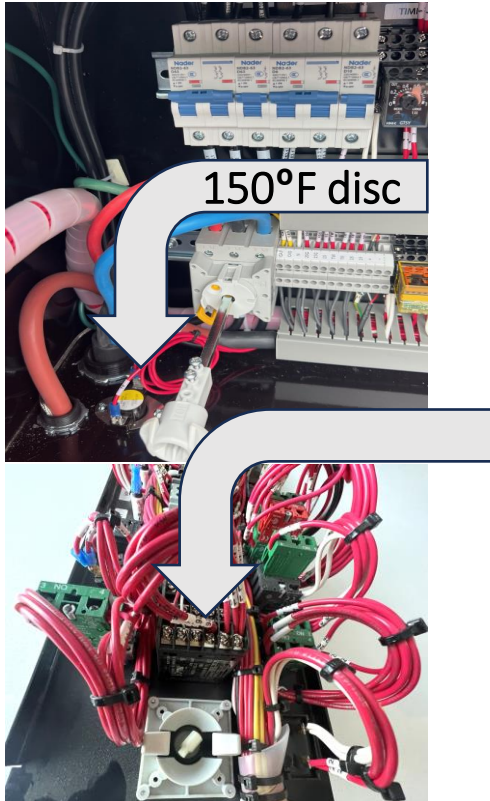

Temperature controller

[HOME](#)

1. Turn off power to the heater.
 2. Remove wire **#10** from the 150°F thermal limit disc.
 3. Restore power to the heater.
 4. Reset the 'overheat reset' button
- ✓ If the burner starts, the 150°F thermal limit disc is defective.
- If the overheat reset still stays illuminated.
1. Turn off power to the heater.
 3. Remove the **#10** wire from the temperature controller.
 4. Restore power to the heater.
- ✓ Reset the 'overheat reset' button If the burner starts, the temperature controller is defective.
 - ✓ If the 'overheat reset' remains illuminated, the LR relay is defective.

Problem Solved



Choose the information you are looking for and click on the Page #

- Set up procedure...[Page 42](#)
- Start-up procedure...[Page 47](#)
- Adjusting the air settings and pump pressure...[Page 52](#)
- Electrical hook up...[Page 45](#)
- Venting the heater...[Page 43](#)
- Adjusting the burner combustion...[Page 50](#)
- Electrode adjustments...[Page 53](#)
- **Caution:** Why heatexchangers **Implode**...[Page 54](#)
- Pre-season annual maintenance...[Page 60](#)

[HOME](#)



1

The heater should be installed level, and on solid ground or base.

2

The heater should be installed on a noncombustible base (material).

3

The heater should not be installed in an area where combustible gases are circulating.

4

The heater must be equipped with vent (flue) pipes installed. See venting...[Page 43](#)

5

The heater should have the proper size wiring for voltage and amperage demand...[Page 45](#)

6

All gas piping and wiring cables should be routed so they are protected from water or traffic.

7

Ensure all piping and fittings are free from gas leaks.

8

Ensure proper ducting of heater respecting limitations...[Page 46](#)

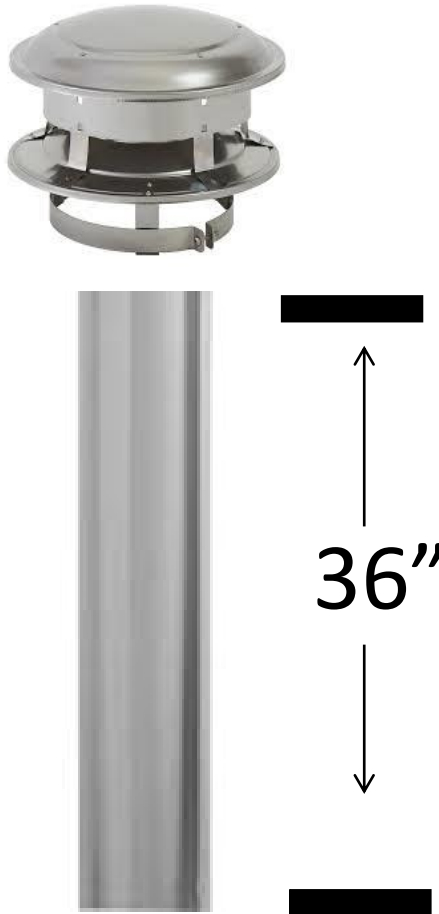

- Make sure to install a stack minimum 30” on the flue.
- Make sure to install a rain cap on the flue pipe.
- Make sure that flue gases are not being recirculated into the blower fan and pushed into the space you are heating.

WARNING: The appropriate measures must be taken to ensure there will be no positive pressures on the exhaust flue of the heater.

➤ Venting from inside a building...[Page 44](#)

➤ Back to technical menu...[Page 41](#)

Best practices for venting when heater is located inside a building

- Avoid using as many 90-degree elbows as possible
- Venting runs should be as short as possible
- Vertical rise minimum 3 feet, 5 feet is better outside the building.
- 20 feet maximum flue run and always install a rain cap.

- Never decrease diameter of flue piping.
- Horizontal runs $\frac{1}{4}$ " per foot rise.
- Make sure all piping is properly secured.
- Make sure there is no negative pressure inside the building where the heater is placed.

➤ **Note:** where the vent pipe passes through a combustible wall a fireproof thimble must be used.





- **All wiring and connections** to the heater should be calculated by a qualified electrician and approved by the local authorities having jurisdiction.

Note: The proper voltage and amperage draw is specified on the rating plate of the heater, failure to comply with electrical standards for wiring and amperage draw of the heater may cause damage to the heater. Consult a qualified electrician for assistance in wire sizing.

Back to technical menu... [Page 41](#)



The EB1000G can be used in most applications with ductwork.

The maximum outlet (supply air) is 400 feet. The **maximum** inlet (return air) is 50 feet.

Total ducting, Outlet plus Inlet **not to exceed 400** feet.

➤ Best practices...

- ✓ Never exceed the 400 feet of total ducting and 50 feet of air inlet ducting.
- ✓ If flexible ducting is used, there should be no kinks in ductwork.
- ✓ Weather flexible or solid ducting is used, try to avoid sharp 90° turns.
- ✓ If ducting is split into 2 locations, use a TY not a T. and a maximum of 200 feet total ducting.
- ✓ If ducting is split into 2 locations, ensure the volume of air passing through is equal to or greater than the single outlet of the heater.
- ✓ Ensure all ducting is properly protected from water, traffic, and other obstructions.
- **Note:** Improper ducting will cause overheating and short cycling which will damage the heater and void all warranty.

Back to technical menu... [Page 41](#)



1. Determine whether the unit will be powered with **3PH 208V** or **1PH 240V** and follow wiring instructions stipulated on the main serial number decal.
2. Tap control transformer located in control panel for **208V or 240V** according to your power supply voltage.
4. Be sure to fit the unit with a **36"** stack on the flue with **rain cap**. Make sure there will be no negative air pressure when installed inside a building and take the appropriate measures to avoid negative pressures on the flue of the heater. Be sure to always terminate any flue stack set ups in a 3 - foot vertical position and follow the instructions on the decal/diagram located on the heater or manual for longer stack runs. Also, when running the unit for the first time make sure that flue gases are not being sucked in by the cooling fan and pushed into the space you are heating.

➤ Continue start up procedure...[Page 48](#)



- 1. Power up heater. Turn main switch “ON” and controls “ON”. If running without a thermostat leave toggle switch in bypass position, if running with a thermostat then place toggle switch in thermostat position.
- 2. It is imperative to check control voltage when the unit’s cooling fan is running in high speed (Fan speed 3). With your voltmeter or using the heaters panel mounted voltmeter in the control voltage position ensure that the control voltage is not less than 108 Volts and not more than 132 Volts when fan is running at full speed.
- 3. Turn the switch to the “Heat” position. Burner will cycle on and purge the heat exchanger before ignition, Once the burner is running make sure that the oil pressure is adjusted to the manufacture’s recommendations 160 Psi

➤ Start-up continued...[Page 49](#)



Clean & Reliable Combustion

Getting the most reliable performance out of a gas burner comes down to ensuring that it is properly set up. This can require some fine tuning, but the following steps should help you achieve the reliable combustion you are looking for.

➤ **No installation** is complete until the combustion of the heater has been performed.

Using a Combustion analyzer...[Page 50](#)

[HOME](#)



- While the flue-stack is still cold pre-drill ¼" hole in the flue-stack 18" above the flue collar. Set the air settings to manufacture's recommendations. Once you've done that, start the burner and let it operate for **10 minutes**. Draw a smoke sample from the flue pipe. Adjust the air settings to achieve between trace and number **1 smoke**.. Next, draw a carbon dioxide (**CO₂**) sample from the flue pipe. Adjust the air settings to achieve between **11.5% & 12% CO₂**. Check the **CO (Carbon Monoxide)** level, it should not be higher than **50 PPM**.



Smoke Tester



Combustion Analyzer

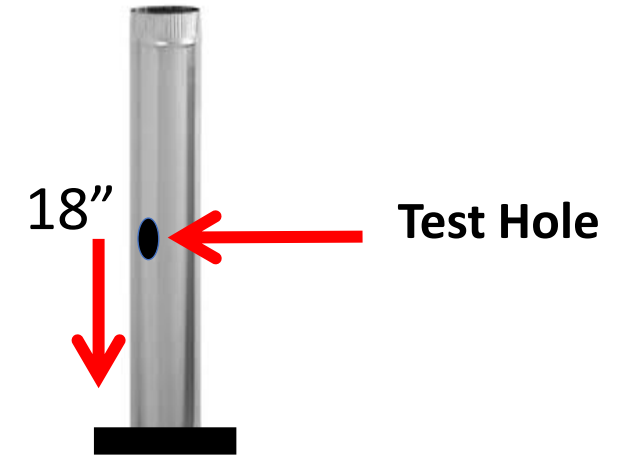

Clean & Reliable Combustion Oil

➤ **Note:** Be sure to set your analyzer for Gas, or Propane.

Set the air settings to manufacturer's recommendations... [Page 52](#) Start the burner and let it operate for 10 minutes. Adjust the air settings to achieve between 11.5% to 12% CO₂ (Carbon dioxide). Check the CO (Carbon Monoxide) level, it should not be higher than 50 PPM.

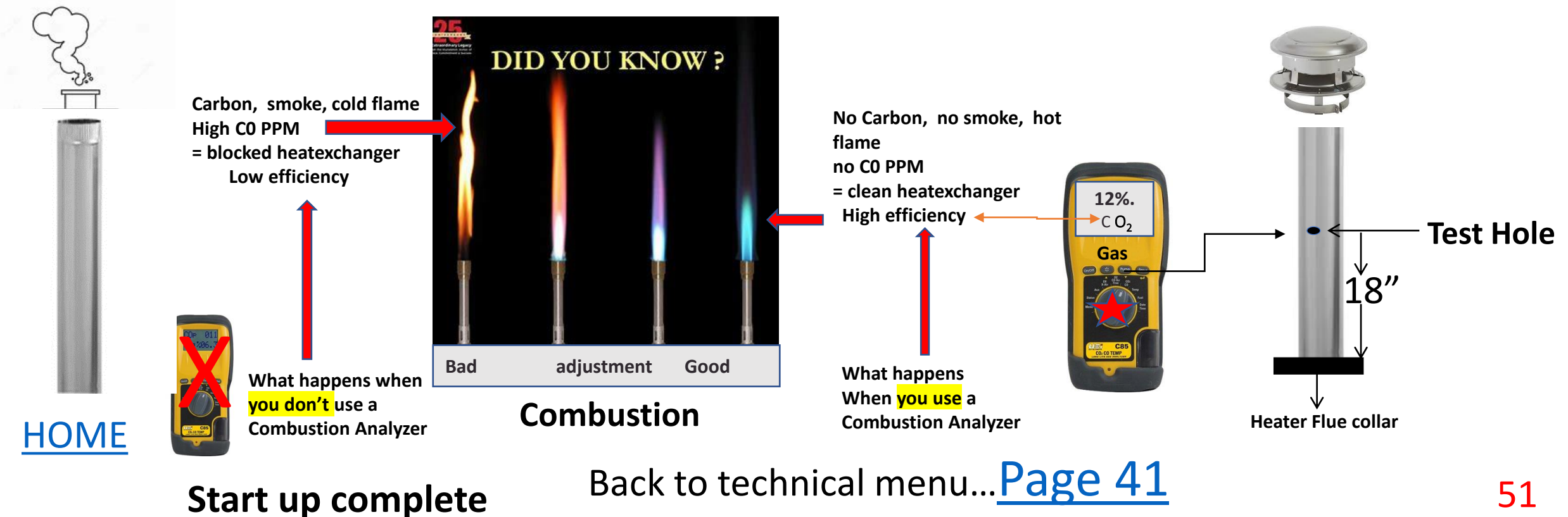

Combustion and adjusting the air settings.



Proper air adjustments must be preformed for reliable combustion

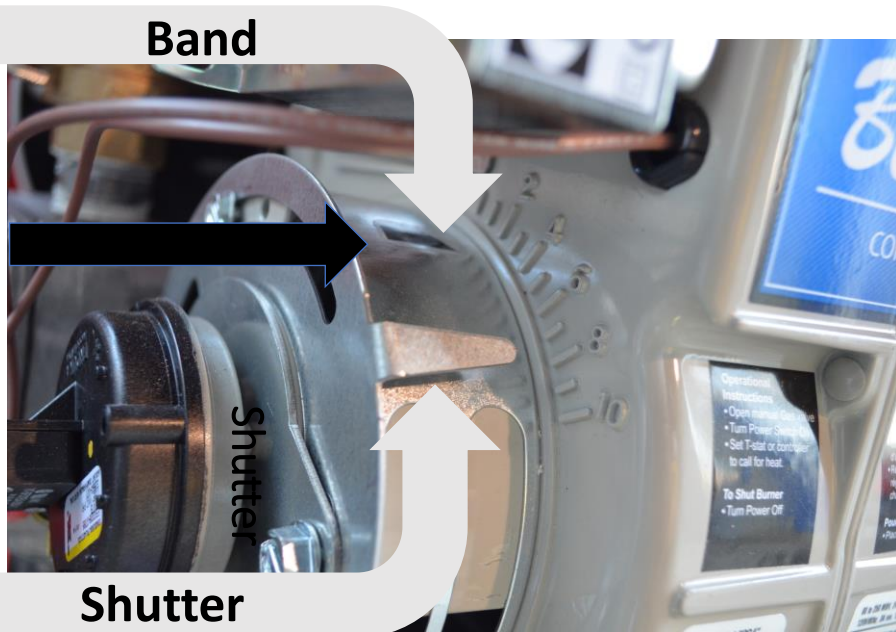

- Recommended air settings are indicated in manufactures instructions **4/0** the first number being the shutter and the **second** number being the band.
 - **Note:** recommend air settings are approximate and will change with altitude and fuel oil temperature.
 - **The Use of a combustion analyzer** will ensure clean and reliable burning and maximum efficiency.
 - **EB1000D** Air setting **4/0**, Oil pressure is **160** PSI. Head setting **# 4**

Back to technical menu... [Page 41](#)

[HOME](#)

Electrode Adjustments

➤ EB 600-700-1000D... (P = 3/16") (Q = 1/4") (R = 3/16" gap)

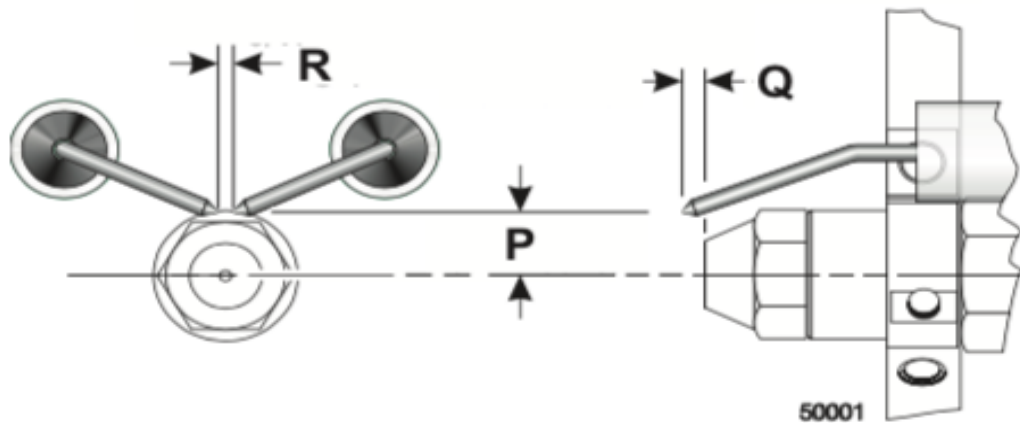

➤ EB1000D Air setting 10/5, Oil pressure is 160 PSI. Head setting # 5

Legend (Figure 5)

- P Nozzle centerline to electrode tip = 3/16"
- Q Nozzle face to electrode tip = 1/4"
- R Electrode spacing = 3/16" gap

Back to technical menu... [Page 41](#)



To start you should know fuel oil as a liquid does not burn. The liquid fuel must be heated up to its ignition point (**104°F** for most fuel oils used in heating appliances) and then it can be ignited. This means a cold heatexchanger that is flooded with raw fuel will not implode when first started up. The accumulated raw fuel in the heaterexchanger would have to be over **104°F** to be in a vapor state. The most common reasons for implosions are:

1. Excessive resetting of the burner safety control and flooding the heater. Finding the issue then re-starting and realize it is flooded and shutting it off and re-starting it while it is still hot.
2. **Human error**, starting a flooded heater not knowing it is flooded and letting it heat up and then realizing it is, and shutting it off and re-starting it while it is still hot.
3. Fuel oil nozzles being partially blocked and still firing but spilling raw fuel to the bottom of the heatexchanger, shutting down on high limit then starting up as it cools down. In this case you would notice a lot of black smoke spilling from the stack and eventually the heatexchanger will fill up with soot that is wet with raw fuel oil. Left in this condition for a period of time could cause an implosion.



Understanding implosions happen when heatexchangers have an excessive amount of fuel oil in them and the fuel is heated up above the ignition point, we must ensure...

- ✓ Never start and stop the heater while it is flooded with raw fuel.
- ✓ Never continue to reset the control more than 3 time.
- ✓ Always make sure there is no accumulation of fuel when resetting the control.
- ✓ If the heater is spilling a lot of black smoke, shut it down and correct the problem.
- ✓ Ensure a pre-season annual maintenance is preformed.
- ✓ Ensure the operator of the heater is aware of the potential danger.



- **Note:** Usually when the thermocouple is defective, the Temperature Controller will indicate odd readings in the display window.

Example.. 0000 or high numbers, 700 or 800

In this case....



- **Testing the thermocouple...**

Remove the (small) red and white thermocouple wires from the terminal block located in the control panel on **#11** white and **#12** red. Place a jumper wire between the two terminals **#11** And **#12. on** the temperature controller

- ✓ if now the display reads the ambient temperature, defective thermocouple
- ✓ If the display continues to read odd numbers, defective temperature controller



Tech Tip

With the side panels removed.



1. Remove thermocouple wire from the bottom of the terminal block in the panel.
2. Attach a string to the end of the wires using electrical tape insuring the knot is not too large.
3. Locate the chase that the thermocouple passes through in the heater casing.
4. Using a box cutter cut a 4 inch slit in the chase casing. (**careful not to cut into wires inside**).
5. Locate the thermocouple wire through the slit.
6. Pull the thermocouple wire through the slit while someone else pushes it from panel.
7. Once the string reaches the slit have someone pull the thermocouple from the burner end of the heater while someone pushes it through the slit.
8. With the old thermocouple removed attach the string onto the new thermocouple wires insuring electrical tape insuring the knot is not too large.
9. Now reverse the procedure and reinstall the wires to the terminal block, white to white, red to red.

Back to technical menu... [Page 41](#)



Tech Tips And Bulletins and more for You...

Don't get left behind. Stay on the top of your game and become a...
“ Campo Field Assist Program Member”.

- As a member you will receive updates and notifications of any changes to the Guides.
- As a member you will be notified of upcoming courses.
- As a member you will be first to receive any new “Field Assist Troubleshooting Guides”
- As a member you will receive more “Tips” to make your job easier.

“It’s quick, simple and easy, join us today”



www.campoequipment.com/TECHSUPP

[HOME](#)



We pride ourselves in offering...
The best technical support in the industry

[HOME](#)



sales@campoequipment.com



1-866-323-0042

Pre-season checklist oil fired Heaters:



SERIAL NUMBER:	Test DATE:
Model	/ /
Tested By:	
Oil Burner	
Preform and Record combustion results:	
CO2 PERCENTAGE (carbon dioxide)	
CO parts per million (ppm carbon monoxide)	
Remove nozzle line assembly adjust electrodes and clean	
Replace nozzle (if necessary)	
Remove cad cell and clean glass eye	
Test igniter	
Start burner and check control lock-out	
Check and adjust oil pressure	
Clean blower wheel (remove dust)	
Continue... Page 61	

Pre-season checklist oil fired Heaters:



Heater controls	
Test temperature controller Fan on at 90F / Fan off at 80F Burner off 10F above set high limit / Burner back on at high set temp	
Check circulating fan,(Fan timer, Fan relay, 110F disk)	
Check wiring terminals inside control panel	
Clean heater casing	
Back to technical menu... Page 41	